



SPECTRA SL3 LIBRARY USER GUIDE



SpectraLogic.com

COPYRIGHT

Copyright © 2025-2026 Spectra Logic Corporation. All rights reserved. This item and the information contained herein are the property of Spectra Logic Corporation.

NOTICES

Except as expressly stated herein, Spectra Logic Corporation makes its products and associated documentation on an “AS IS” BASIS, WITHOUT WARRANTY OF ANY KIND, EITHER EXPRESSED OR IMPLIED, INCLUDING BUT NOT LIMITED TO THE IMPLIED WARRANTIES OF MERCHANTABILITY OR FITNESS FOR A PARTICULAR PURPOSE, BOTH OF WHICH ARE EXPRESSLY DISCLAIMED. In no event shall Spectra Logic be liable for any loss of profits, loss of business, loss of use or data, interruption of business, or for indirect, special, incidental or consequential damages of any kind, even if Spectra Logic has been advised of the possibility of such damages arising from any defect or error.

Information furnished in this manual is believed to be accurate and reliable. However, no responsibility is assumed by Spectra Logic for its use. Due to continuing research and development, Spectra Logic may revise this publication from time to time without notice, and reserves the right to change any product specification at any time without notice.

TRADEMARKS

Attack Hardened, BlackPearl, BlueScale, RioBroker, Spectra, SpectraGuard, Spectra Logic, Spectra Vail, StorCycle, TeraPack, TFinity, and TranScale are registered trademarks of Spectra Logic Corporation. All rights reserved worldwide. All other trademarks and registered trademarks are the property of their respective owners.

PART NUMBER

90970047 Revision C

REVISION HISTORY

Revision	Date	Description
A	November 2025	Initial release.
B	February 2026	Updated with minor corrections.
C	April 2026	Updated half-height drive technical information.

- Notes:**
- To make sure you have the most current version of this guide check the Spectra Logic Technical Support portal at support.spectralogic.com/documentations/user-guides/.

END USER LICENSE AGREEMENT

1. READ CAREFULLY

YOU SHOULD READ THE FOLLOWING TERMS AND CONDITIONS BEFORE ACCEPTING THIS END-USER LICENSE AGREEMENT ("EULA"). THIS EULA IS A LEGAL AGREEMENT BETWEEN YOUR ORGANIZATION, THE END USER, AND SPECTRA LOGIC CORPORATION ("SPECTRA") FOR THE SPECTRA SOFTWARE PRODUCT WHICH INCLUDES COMPUTER SOFTWARE AND MAY INCLUDE ASSOCIATED MEDIA, PRINTED MEDIA, AND "ONLINE" OR ELECTRONIC DOCUMENTATION (COLLECTIVELY, "SOFTWARE PRODUCT"). BY INSTALLING, COPYING, OR OTHERWISE USING THE SOFTWARE PRODUCT, YOU AGREE TO BE BOUND BY THE TERMS OF THIS EULA. IF YOU DO NOT AGREE TO THE TERMS OF THIS EULA, YOU MAY NOT INSTALL, COPY, DOWNLOAD OR USE THE SOFTWARE PRODUCT. YOU AGREE THAT YOUR USE OF THE SOFTWARE ACKNOWLEDGES THAT YOU HAVE READ THIS AGREEMENT, UNDERSTAND IT, AND AGREE TO BE BOUND BY ITS TERMS AND CONDITIONS.

2. OWNERSHIP

It is understood and agreed that Spectra Logic Corporation, a Delaware corporation with offices at 6285 Lookout Road, Boulder, CO 80301 ("Licensor") is the owner of all right, title and interest to the Software Product, regardless of the media or form of the original download, whether by the World Wide Web, disk or otherwise. You, as licensee ("Licensee") through your downloading, installing, copying or use of this product do not acquire any ownership rights to the Software Product.

3. GENERAL

The Software Product is licensed, not sold, to you by Spectra for use only under the terms of this EULA. The Software Product is protected by copyright laws and international copyright treaties, as well as other intellectual property laws and treaties. The rights granted herein are limited to Spectra's and its licensors' intellectual property rights in the Software Product and do not include any other patents or intellectual property rights. The terms of this EULA will govern any software upgrades provided by Spectra that replace and/or supplement the original Software Product, unless such upgrade is accompanied by a separate license in which case the terms of that license will govern.

4. SOFTWARE PRODUCT

The Software Product, as used in this EULA, means, collectively and/or as applicable:

- The Software Product package;
- Any and all contents, components, attachments, software, media, and code with which this Agreement is provided and delivered;
- Any and all images, photographs, art, art work, clip art, fonts or other artistic works (the "Art Work");
- Related explanatory written materials and instructions, and any other possible documentation related thereto ("Documentation"); and
- Upgrades, modified versions, updates, additions and copies of the Software Product (the "Upgrades"), if any, licensed to by Spectra under this EULA.

5. GRANT OF LICENSE AND RESTRICTIONS

- A. Spectra grants you a non-exclusive, non-transferable End-User license right to install the Software Product solely for the purpose for which it was created.
- B. Unless provided otherwise in the Documentation or by prior express written consent of Spectra, you shall not display, modify, reproduce and distribute any Art Work, or portion(s) thereof, included with or relating to the Software Product, if any. Any such authorized display, modification, reproduction and distribution shall be in full accord with this EULA. Under no circumstances will your use, display, modification, reproduction and distribution of the Art Work give you any Intellectual Property or Proprietary Rights of the Art Work. All rights, title, and interest belong solely to Spectra.
- C. Except for the initial loading of the Software Product, you shall not, without Spectra's express written consent:
 - Copy or reproduce the Software Product; or
 - Modify, adapt, or create derivative works based on the Software Product or any accompanying materials.

6. DESCRIPTION OF OTHER RIGHTS AND LIMITATIONS

- A. Spectra will provide you with support services related to the Software Product ("Support"). Such Support will be provided in accordance with the Spectra Master Support Agreement, available for download and viewing on the Spectra Corporate Web site. Use of Support is governed by this EULA and Spectra's Master Support Agreement.
- B. Any supplemental software, code, content, or media provided to you in the course of Support shall be considered part of the Software Product and subject to the terms and conditions of this EULA.
- C. Spectra retains all right, title, and interest in and to the Software Product, and any rights not granted to you herein are reserved by Spectra. You hereby expressly agree not to extract information, reverse engineer, disassemble, decompile, or translate the Software Product, or otherwise attempt to derive the source code of the Software, except to the extent allowed under any applicable law. In the event that such activities are permitted by applicable law, any information you, or your authorized agent, discover shall be promptly disclosed to Spectra and shall be deemed the confidential information of Spectra.
- D. You shall not modify, sublicense, assign, or transfer the Software Product or any rights under this EULA, except as expressly provided in this EULA. Any attempt to sublicense, assign, or transfer any of the rights, duties, or obligations will be void.
- E. You may permanently transfer all of your rights under this EULA, provided you retain no copies. The other party must agree to accept the terms and conditions of the EULA.

7. ALL RESERVED

All rights not expressly granted herein are reserved by Spectra.

8. TERM

- A. This License is effective until terminated. Licensee may terminate it at any time by destroying the Software Product with all copies, full or partial, and removing all of its component parts.
- B. Your rights under this EULA will terminate automatically without notice from Spectra if you fail to comply with any term(s) or condition(s) of this EULA. In such event, no notice shall be required by Spectra to effect such termination.
- C. Upon termination of this EULA, you shall cease all use of the Software Product and destroy all copies, full or partial, together with all backup copies, modifications, printed or written materials, and merged portions in any form and remove all component parts of the Software Product.

9. INTELLECTUAL PROPERTY RIGHTS

- A. Spectra shall retain all right, title, and interest in the Software Product and to any modifications or improvements made thereto, and any upgrades, updates or Documentation provided to End User. End User will not obtain any rights in the Software Product, its updates, upgrades, and Documentation, as a result of its responsibilities hereunder.
- B. End User acknowledges Spectra's exclusive rights in the Software Product and that the Software Product is unique and original to Spectra and that Spectra is owner thereof. Unless otherwise permitted by law, End User shall not, at any time during or after the effective Term of the Agreement, dispute or contest, directly or indirectly, Spectra's exclusive right and title to the Software Product or the validity thereof.

10. U.S. GOVERNMENT END USERS

The Software Product and related documentation are "Commercial Items," as that term is defined at 48 C.F.R. §2.101, consisting of "Commercial Computer Software" and "Commercial Computer Software Documentation," as such terms are used in 48 C.F.R. §12.212 or 48 C.F.R. §§227.7202-1 through 227.7202-4, as applicable. The Commercial Computer Software and Commercial Computer Software Documentation are being licensed to U.S. Government end users (a) only as Commercial Items and (b) with only those rights as are granted to all other End Users pursuant to the terms and conditions herein. Unpublished rights reserved under the copyright laws of the United States.

11. EXPORT LAW ASSURANCES

You may not use or otherwise export or re-export the Software Product except as authorized by United States law and the laws of the jurisdiction in which the Software Product was obtained. In particular, but without limitation, the Software Product may not be exported or re-exported (a) into (or to a nation or resident of) any U.S. embargoed countries or (b) to anyone on the U.S. Treasury Department's list of Specially Designated Nationals or the U.S. Department of Commerce Denied Persons List or Entity List. By installing or using any component of the Software Product, you represent and warrant that you are not located in, under control of, or a national or resident of any such country or on any such list.

12. DISCLAIMER OF WARRANTIES

YOU EXPRESSLY ACKNOWLEDGE AND AGREE THAT USE OF THE SOFTWARE PRODUCT IS AT YOUR SOLE RISK AND THAT THE ENTIRE RISK AS TO SATISFACTORY QUALITY, PERFORMANCE, ACCURACY AND EFFORT IS WITH YOU. TO THE MAXIMUM EXTENT PERMITTED BY APPLICABLE LAW, AND EXCEPT AS MAY BE STATED IN THE SPECTRA MASTER SERVICE AGREEMENT, THE SOFTWARE PRODUCT IS PROVIDED "AS IS," WITH ALL FAULTS AND WITHOUT WARRANTY OF ANY KIND, AND SPECTRA AND SPECTRA'S AFFILIATES (COLLECTIVELY REFERRED TO AS "SPECTRA" FOR THE PURPOSES OF SECTIONS 12 AND 13) HEREBY DISCLAIM ALL WARRANTIES AND CONDITIONS WITH RESPECT TO THE SOFTWARE PRODUCT, EITHER EXPRESS, IMPLIED OR STATUTORY, INCLUDING, BUT NOT LIMITED TO, THE IMPLIED WARRANTIES AND/OR CONDITIONS OF MERCHANTABILITY, OF SATISFACTORY QUALITY, OF FITNESS FOR A PARTICULAR PURPOSE, OF ACCURACY, OF QUIET ENJOYMENT, AND NON-INFRINGEMENT OF THIRD-PARTY RIGHTS. SPECTRA DOES NOT WARRANT AGAINST INTERFERENCE WITH YOUR ENJOYMENT OF THE SOFTWARE PRODUCT THAT THE FUNCTIONS CONTAINED IN THE SOFTWARE PRODUCT WILL MEET YOUR REQUIREMENTS, THAT THE OPERATION OF THE SOFTWARE PRODUCT WILL BE UNINTERRUPTED OR ERROR-FREE, OR THAT DEFECTS IN THE SOFTWARE PRODUCT WILL BE CORRECTED. NO ORAL OR WRITTEN INFORMATION OR ADVICE GIVEN BY SPECTRA OR A SPECTRA AUTHORIZED REPRESENTATIVE SHALL CREATE A WARRANTY. SOME JURISDICTIONS DO NOT ALLOW THE EXCLUSION OF IMPLIED WARRANTIES OR LIMITATION ON APPLICABLE STATUTORY RIGHTS OF A CONSUMER, SO THE ABOVE EXCLUSION AND LIMITATIONS MAY NOT APPLY TO YOU.

13. LIMITATION OF LIABILITY

TO THE MAXIMUM EXTENT PERMITTED BY APPLICABLE LAW, IN NO EVENT SHALL SPECTRA, ITS AFFILIATES OR LICENSEES, BE LIABLE FOR ANY SPECIAL, INCIDENTAL, INDIRECT, OR CONSEQUENTIAL DAMAGES WHATSOEVER (INCLUDING, WITHOUT LIMITATION, DAMAGES FOR LOSS OF BUSINESS PROFITS, BUSINESS INTERRUPTION, LOSS OF BUSINESS INFORMATION, OR ANY OTHER PECUNIARY LOSS) ARISING OUT OF THE USE OF OR INABILITY TO USE THE SOFTWARE PRODUCT OR THE PROVISION OF OR FAILURE TO PROVIDE SUPPORT SERVICES, EVEN IF SPECTRA HAS BEEN ADVISED OF THE POSSIBILITY OF SUCH DAMAGES. IN ANY CASE, SPECTRA'S ENTIRE LIABILITY UNDER ANY PROVISION OF THIS EULA SHALL BE LIMITED TO THE AMOUNT ACTUALLY PAID BY YOU FOR THE SOFTWARE PRODUCT; PROVIDED HOWEVER, IF YOU HAVE ENTERED INTO A MASTER SUPPORT AGREEMENT, SPECTRA'S ENTIRE LIABILITY REGARDING SUPPORT SERVICES SHALL BE GOVERNED BY THE TERMS OF THAT AGREEMENT. BECAUSE SOME STATES AND JURISDICTIONS DO NOT ALLOW THE EXCLUSION OR LIMITATION OF LIABILITY, THE ABOVE LIMITATION MAY NOT APPLY TO YOU.

14. CONTROLLING LAW AND SEVERABILITY

This EULA will be governed by and construed in accordance with the laws of the State of Colorado, as applied to agreements entered into and to be performed entirely within Colorado between Colorado residents. This EULA shall not be governed by the United Nations Convention on Contracts for the International Sale of Goods, the application of which is expressly excluded. If for any reason a court of competent jurisdiction finds any provision, or portion thereof, to be unenforceable, the remainder of this EULA shall continue in full force and effect.

SYSTEM BIOS

Resetting the system BIOS when not authorized by Spectra Logic Technical Support invalidates the system configuration. Spectra Logic reserves the right to charge for time and materials to reconfigure and recertify the system.

CONTACTING SPECTRA LOGIC

To Obtain General Information	
Spectra Logic Website: spectralogic.com	
United States Headquarters	European Office
Spectra Logic Corporation 6285 Lookout Road Boulder, CO 80301 USA Phone: 1.800.833.1132 or 1.303.449.6400 International: 1.303.449.6400 Fax: 1.303.939.8844	Spectra Logic Europe Ltd. 329 Doncastle Road Bracknell Berks, RG12 8PE United Kingdom Phone: 44 (0) 870.112.2150 Fax: 44 (0) 870.112.2175
Spectra Logic Technical Support	
Technical Support Portal: support.spectralogic.com	
United States and Canada Phone: Toll free US and Canada:1.800.227.4637 International: 1.303.449.0160	Europe, Middle East, Africa Phone: 44 (0) 870.112.2185 Deutsch Sprechende Kunden Phone: 49 (0) 6028.9796.507
Additional international numbers available at support.spectralogic.com/home If you have a Spectra Logic Portal account, please log in for country-specific numbers at support.spectralogic.com/support-contact-info	
Spectra Logic Sales	
Website: shop.spectralogic.com	
United States and Canada Phone: 1.800.833.1132 or 1.303.449.6400 Fax: 1.303.939.8844 Email: sales@spectralogic.com	Europe Phone: 44 (0) 870.112.2150 Fax: 44 (0) 870.112.2175 Email: eurosales@spectralogic.com
To Obtain Documentation	
support.spectralogic.com/documentations	

Contents

About This Guide	14
Document Purpose	14
Product Warranty Caution	14
General Warnings	15
Document Conventions	15
General Product Warnings	16
Acronyms and Abbreviations	19
Additional Publications	20
BlueVision User Interface Screens	20
Chapter 1 - Product Overview	21
Supported Library Configurations	22
Front Panel	23
Rear Panel	25
Tape Drive Back Panels	27
iADT Drive Sleds Back Panel	28
Power Supply Back Panel	30
Element Numbering	31
Tape Cartridges	32
Using and Maintaining Tape Cartridges	33
Labeling Tape Cartridges	34
Write Protecting Tape Cartridges	35
Read and Write Compatibility	36
Integration With a BlackPearl System	36
Chapter 2 - Using the BlueVision Interface	37
Using the Operator Control Panel	38
Using the Remote Management Interface	39
Library User Types	40
Logging into the Library	41
Using the Library Main Screen	42
Top Banner Elements	43
Left Pane Elements	44
Right Pane Elements	46

Center Pane Elements	46
Chapter 3 - Configuring the Library	48
Using the Initial Configuration Wizard	50
Saving, Restoring, and Resetting the Library Configuration	51
Saving the Library Configuration	52
Verify the Configuration Backup File	52
Resetting to the Default Settings	54
Configuring the Date and Time Format	55
Setting the Time Zone	56
Setting the Date and Time Format	57
Setting the Date and Time	57
Enabling SNTP (Simple Network Time Protocol) Synchronization	58
Configuring Media Barcode Compatibility Checking	59
Add a License Key	60
Configuring the Library Network Settings	61
Reset the Internal IP Range	63
Configuring SNMP	65
Configuring Event Notification Parameters	68
Configuring Tape Drives	70
Enabling or Disabling Mailslots	72
Configuring Library Partitions	73
Using the Basic Partition Wizard	73
Using the Expert Partition Wizard	76
Configure Encryption	78
KMIP Wizard	78
Configure User Accounts	84
Configure User Account Settings	84
Configure Local User Accounts	86
Configure LDAP	91
Web Management	95
Security Certificates	95
Session Timeout	98
OCP/RMI Session Locking	98
Restrict RMI Access	99

Chapter 4 - Operating the Library	100
Moving Media	101
Filtering Based on Barcode	101
Moving a Cartridge	102
Opening the Mailslot	103
Opening a Magazine	104
Cleaning a Tape Drive	105
Forcing a Drive to Eject a Cartridge	106
Rescanning the Cartridge Inventory	107
Chapter 5 - Viewing Library Status	108
Viewing Library and Module Status	109
Using Inventory Lists	112
Filtering by Barcode Label	114
Listing Just Drives or Cartridges	114
Viewing Elements by Group	114
Using the Cartridge Inventory Graphical View	115
Using Partition Map Graphical View	117
Using Partition Map Configuration Status	119
Viewing Drive Status	121
Viewing Network Status	124
Viewing Encryption Status	126
Chapter 6 - Maintaining the Library	127
Library Tests	128
System Test	128
Slot to Slot Test	129
Element to Element Test	130
Position Test	132
Wellness Test	133
Robotics Test	134
OCP Test and Calibration	134
Logs and Traces	135
Viewing Log Files	135
Downloading Log and Trace Files	136
Configuring Remote Logging	136

Software Upgrades	138
Managing System Firmware	138
Managing Drive Firmware	140
Downloading Drive Logs	143
Rebooting the Library	143
Rebooting Drives	144
Controlling the UID LED	145
Moving the Robotic Assembly to the Base Module	146
LTO-9 New Media Initialization	147
Chapter 7 - Library Troubleshooting	150
Fibre Channel Connection Problems	151
Detection Problems after Installing a SAS Drive	152
Operation Problems	154
Power Problems	154
Failure/Attention Indications Displayed on the Operator Control Panel ..	154
Tape Movement Problems	155
Media Problems	155
Attention LED is Lit	156
Inventory Problems	157
RMI Network Connection Issues	157
Performance Problems	159
Average File Size	159
File Storage System	159
Connection from the Backup/Archive Host Server to a Disk Array	160
Backup/Archive Server	160
Backup/Archive Software and Method	160
Connection from the Archive/Backup Host Server to the Library	161
Media	161
Finding Event Information	161
Unlocking the Magazine	162
Using the OCP or RMI	162
Using the Manual Release	163
Unloading a Stuck Tape	163
Identifying a Failed Component	164

Chapter 8 - Event Codes	165
Error Events	166
Warning Events	176
Configuration Change Events	182
Informational Events	184
Chapter 9 - Technical Support	186
Accessing the Technical Support Portal	187
Create an Account	187
Log Into the Portal	188
Opening a Support Ticket	189
Search for Help Online	189
Submit an Incident Online	192
Submit an Incident by Phone	194
Returns	195
Appendix A - Specifications	196
Physical Specifications	197
Rack Requirements	197
Environmental Specifications	199
Library Environmental Specifications	199
Electrical specifications	200
Regulatory specifications (CSA test conditions)	201
Default Settings	202
Barcode Label Specifications	206
Electrostatic discharge	209
Preventing Electrostatic Damage	209
Grounding Methods	209
Power Consumption and Cooling Requirements	210
LTO Tape Drive Specifications	211
Appendix B - Regulatory Information	215
Recycling and disposal	215
CE mark	215
CCL Mark	215
FCC (United States)	216
Canadian verification	216

ABOUT THIS GUIDE

DOCUMENT PURPOSE

This document provides information to configure, maintain, and troubleshoot the Spectra® SL3 Tape Library. The instructions are intended for the System Administrators and trained Users who need physical and functional knowledge of the SL3 library.

The main components are:

- Controller module: SL3 Base
- Expansion module: EX3 Expansion

PRODUCT WARRANTY CAUTION

Customers should only perform the service and repair actions on the tape library components using replacement instructions available on the Spectra Logic support portal. Any other actions must be performed by authorized service personnel.

The warranty for the tape library shall not apply to failures of any unit when:

- The tape library is repaired or modified by anyone other than the manufacturer's personnel or approved agent.
- The tape library is physically abused or used in a manner that is inconsistent with the operating instructions or product specification defined by the manufacturer.
- The tape library fails because of accident, misuse, abuse, neglect, mishandling, misapplication, alteration, faulty installation, modification, or service by anyone other than authorized service personnel.
- The tape library is repaired by anyone, including approved technicians, in a manner that is contrary to the maintenance or installation instructions supplied by the manufacturer.
- The manufacturer's serial number tag is removed.
- The tape library is damaged because of improper packaging on return.

The warranty becomes immediately void in the event of unauthorized repairs or modifications.

GENERAL WARNINGS

Document Conventions

This document uses the following conventions to highlight important information:



WARNING

Read text marked by the “Warning” icon for information you must know to avoid personal injury.



CAUTION

Read text marked by the “Caution” icon for information you must know to avoid damaging the hardware or losing data.



IMPORTANT

Read text marked by the “Important” icon for information that helps you complete a procedure or avoid extra steps.

Note: Read text marked with “Note” for additional information or suggestions about the current topic.



WARNING

Lisez le texte marqué par l'icône «Avertissement» pour les informations que vous devez connaître pour éviter les blessures.



CAUTION

Lisez le texte marqué par l'icône «Attention» pour obtenir des informations que vous devez connaître pour éviter d'endommager la bibliothèque ou les lecteurs de bande, ou de perdre des données.



IMPORTANT

Lisez le texte marqué par l'icône «Important» pour obtenir des informations qui vous aident à terminer une procédure ou à éviter des étapes supplémentaires.

Remarque: Lisez le texte marqué par «Remarque» pour obtenir des informations supplémentaires ou des suggestions sur le sujet actuel.

General Product Warnings



WARNING

High voltage
Risk of electric shock

- Do not remove covers (top, bottom or rear). No user-serviceable parts are inside.
 - Refer servicing to qualified service personnel.
 - Plug the power cord into a grounded (earthed) electrical outlet that is easily accessible at all times.
-



WARNING

Haute tension
Risque de choc électrique

- Ne retirez pas les capots (supérieur, inférieur ou arrière). Aucune pièce réparable par l'utilisateur ne se trouve à l'intérieur.
 - Confiez l'entretien à un personnel qualifié.
 - Branchez le cordon d'alimentation dans une prise électrique reliée à la terre et facilement accessible à tout moment.
-



WARNING

Product Weight. See [Specifications on page 196](#).

Risk of personal injury

Before lifting a module:

- Observe local health and safety requirements and guidelines for manual material handling.
- Remove all tapes to reduce the weight.
- Remove all tape drives to reduce the weight.
- Obtain adequate assistance to lift and stabilize the module during installation or removal.

Risk of damage to library

When placing a module into or removing the module from a rack:

- Extend the rack's leveling jacks to the floor.
 - Ensure that the full weight of the rack rests on the leveling jacks.
 - Install stabilizing feet on the rack.
 - Extend only one rack component at a time.
-

Poids du produit. Voir [Specifications](#) on page 196.

Risque de blessure corporelle

Avant de soulever un module:

- Respectez les exigences locales en matière de santé et de sécurité et les directives pour la manutention manuelle des matériaux.
- Retirez toutes les bandes pour réduire le poids.
- Retirez tous les lecteurs de bande pour réduire le poids.
- Obtenez une assistance adéquate pour soulever et stabiliser le module pendant l'installation ou le retrait.



WARNING

Risque d'endommagement de la bibliothèque

Lors du placement d'un module dans ou du retrait du module d'un rack:

- Déployez les crics de mise à niveau du rack vers le sol.
- Assurez-vous que tout le poids du rack repose sur les vérins de mise à niveau.
- Installez les pieds de stabilisation sur le rack.
- Prolongez un seul composant de rack à la fois.



WARNING

In earthquake- prone areas, the rack must have stabilizing equipment or be anchored to the floor to eliminate the risk of tipping, which could lead to personal injury.



WARNING

In erdbebengefährdeten Gebieten muss das Rack stabilisierende Ausrüstung oder am Boden verankert, um die Kippgefahr, die zu Verletzungen führen können beseitigt werden.



WARNING

Dans les zones sujettes aux tremblements de terre, le rack doit être équipé d'un équipement de stabilisation ou être ancré au sol pour éliminer le risque de basculement, qui pourrait entraîner des blessures.



WARNING

Only trained personnel should operate this equipment. Read all documentation and procedures before installation or operation. This product is intended for installation and operation in a computer rack with the front and rear doors closed and secured. Only personnel with technical and product safety training should be provided access to the library. Such personnel are referred to as users throughout this document. Do not insert any tools or any part of your body into openings of an operating library.



WARNING

Seul un personnel formé doit utiliser cet équipement. Lisez toute la documentation et les procédures avant l'installation ou l'utilisation. Ce produit est conçu pour être installé et utilisé dans un rack d'ordinateur avec les portes avant et arrière fermées et sécurisées. Seul le personnel ayant une formation technique et sur la sécurité des produits doit avoir accès à la bibliothèque. Ce personnel est appelé utilisateur tout au long de ce document. N'insérez aucun outil ni aucune partie de votre corps dans les ouvertures d'une bibliothèque opérationnelle.



**MECHANICAL
HAZARD**

Danger Risk of hand pinching, can trap hands, fingers and cause serious injury. Keep hands clear during operation.



**DANGER
MÉCANIQUE**

Danger Risque de se coincer la main et de se coincer les mains ainsi que les doigts le tout pouvant entrainer de graves blessures. Gardez les mains à l'écart pendant le fonctionnement.

Achtung:
Vor Öffnen des Gerätes
alle Netzstecker ziehen!

Attention:
Remove all power cords
before opening the unit!

Attention:
Débranchez toutes les fiches d'alimentation avant d'ouvrir l'équipement!



ACRONYMS AND ABBREVIATIONS

Acronym or Abbreviation	Meaning
FC	Fibre Channel
HBA	Host Bus Adapter
HH	Half Height
LUN	Logical Unit Number
OC	Operator Control Panel (the library LCD screen)
RMI	Remote Management Interface (the web interface)
SAN	Storage Area Network
SAS	Serial Attached SCSI
SNMP	Simple Network Management Protocol
SSH	Secure Shell
SSL	Secure Socket Layer
UID	Unit Identification
USB	Universal Serial Bus
WORM	Write Once, Read Many
WWNN	World-Wide Node Name
WWPN	World-Wide Port Name

ADDITIONAL PUBLICATIONS

For additional information about the Spectra SL3 Library and its drives, refer to the publications listed in this section.

Spectra SL3 Library

This guide and the following documents related to the Spectra SL3 Library are available as PDF files on the Spectra Logic website at: support.spectrallogic.com/documentation.

- The [*Spectra SL3 Library Installation and Quick Configuration Guide*](#) provides instructions for installing and configuring basic library functions.

LTO Ultrium Tape Drives

The following documents provide information that is applicable to all IBM LTO tape drives.

- [*IBM Tape Device Drivers Installation and User's Guide*](#)

Note: This guide also provides information about using the IBM Tape Diagnostic Tool (ITDT) to troubleshoot drive problems.

- [*IBM TotalStorage LTO Ultrium Tape Drive: SCSI Reference*](#)

For drive-specific information, search for the product name (for example, LTO 6) on the documentation page on the IBM website. You can also search the IBM Support Portal at: <http://www-947.ibm.com/support/entry/portal/Documentation>.

KMIP

See the documentation specific to your server.

BLUEVISION USER INTERFACE SCREENS

The BlueVision interface changes as new features are added or other modifications are made between software revisions. Therefore, the screens on your library may differ from those shown in this document.

CHAPTER 1 - PRODUCT OVERVIEW

Built with maximum flexibility at its core, the Spectra SL3 tape library meets your backup, archive, and perpetual storage requirements. Designed to be easily installed, expanded, and managed, the Spectra SL3 is rated at 100% duty cycle - meaning it is built to perform in a 24/7 environment.



WARNING

Only trained personnel should operate this equipment. Read all documentation and procedures before installation or operation. This product is intended for installation and operation in a computer rack with the front and rear doors closed and secured. Only personnel with technical and product safety training should be provided access to the library. Such personnel are referred to as users throughout this document. Do not insert any tools or any part of your body into openings of an operating library.

Supported Library Configurations	22
Front Panel	23
Rear Panel	25
Tape Drive Back Panels	27
iADT Drive Sleds Back Panel	28
Power Supply Back Panel	30
Element Numbering	31
Tape Cartridges	32
Using and Maintaining Tape Cartridges	33
Labeling Tape Cartridges	34
Write Protecting Tape Cartridges	35
Read and Write Compatibility	36
Integration With a BlackPearl System	36

SUPPORTED LIBRARY CONFIGURATIONS

All Spectra SL3 library installations begin with the 3U controller module, with capacity for 40 tape cartridges and up to three half-height LTO tape drives. The SL3 library only supports half-height drives.

The Spectra SL3 library is expandable, allowing a user to grow the tape storage capacity as data requirements increase. As data storage needs grow, the Spectra SL3 library can also grow by adding one or more 3U expansion module(s). Each expansion module supports an additional 40 tape cartridges and an additional three half-height LTO tape drives.

Up to 15 expansion modules can be added to a controller module, bringing the total library capacity to 640 tape cartridges with 48 half-height drives.

FRONT PANEL

This section describes the features accessible from the front panel of the library.

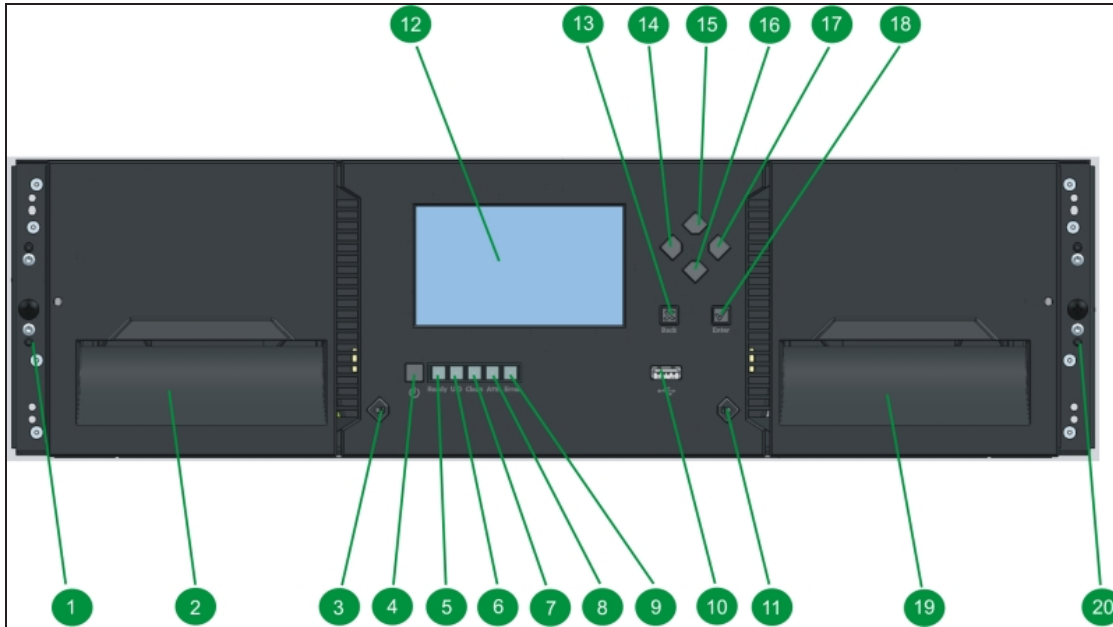

Figure 1 The front view of the Spectra SL3 library.

Number	Component	Description
1	Left Magazine Emergency Release Access Hole	Provides access to the emergency magazine release on the left side of the module.
2	Left Magazine Access Handle	Provides access to the magazine on the left side of the module.
3	Left Magazine Unlock Button	Unlocks the Left Magazine Access Handle.
4	Power Button	Controller Module Only
5	Unit Identification LED, Blue	Controller Module Only
6	Ready LED - Green	Controller Module Only - This LED is steady green when the library is on, and blinks green when there is library robotics activity.
7	Clean LED - Amber	Controller Module Only - This LED illuminates when a tape drive cleaning is needed.

Number	Component	Description
8	Attention LED - Amber	Controller Module Only - This LED illuminates when the library detects a condition which requires manual intervention, but the library can still perform most operations.
9	Error LED - Amber	Controller Module Only - This LED illuminates when the library detects an unrecoverable tape drive or library error and is not capable of operation. Details of the error are displayed on the front panel screen.
10	USB Port	Controller Module Only
11	Right Magazine Unlock Button	Unlocks the Right Magazine Access Handle.
12	Operator Control Panel Display	Controller Module Only
13	Back/Return Button	Controller Module Only
14	Navigation Button - Left	Controller Module Only
15	Navigation Button - Up	Controller Module Only
16	Navigation Button - Down	Controller Module Only
17	Navigation Button - Right	Controller Module Only
18	Enter Button	Controller Module Only
19	Right Magazine Access Handle	Provides access to the magazine on the right side of the module.
20	Right Magazine Emergency Release Access Hole	Provides access to the emergency magazine release on the right side of the module.

REAR PANEL

This section describes the features accessible from the rear panel of the library.

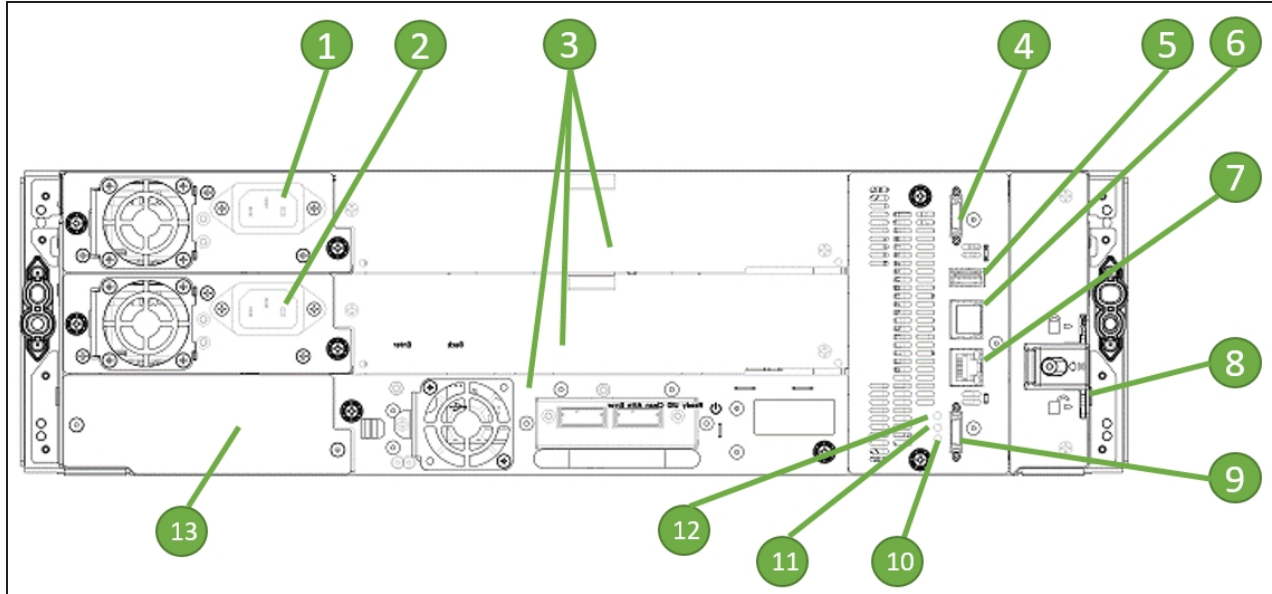

Figure 2 The rear view of the Spectra SL3 library.

Number	Component	Description
1	Power Supply 1	Standard on Controller Module. Optional on Expansion Module.
2	Power Supply 2	Optional on Controller Module. Optional on Expansion Module.
3	Drive Bays	Half-height drive bays shown.
4	Upper Expansion Module Connection Port	If there is a module above this module, a cable connects from this port to the Lower Expansion Module Connection Port in the upper module.
5	USB Port	Optional on Controller Module Only
6	Ethernet Port A	Controller Module Only
7	Ethernet Port B	Optional on Controller Module Only
8	Module Alignment Mechanism	When there is an expansion module below this module, the alignment mechanism is extended to lock into the lower module.

Number	Component	Description
9	Lower Expansion Module Connection Port	If there is a module below this module, a cable connects from this port to the Upper Expansion Module Connection Port in the lower module.
10	Unit Identifier LED - Blue	
11	Controller Error LED - Yellow	Indicates the module controller is experiencing an error.
12	Controller Health Status LED - Green	Indicates the module controller is operating normally.
13	Product Serial Number Tag Location	The product serial number.

TAPE DRIVE BACK PANELS

This section describes the elements of LTO tape drives used in the library.

IBM LTO-6/7/8/9 Half-Height SAS Dual Port Drive

	1	SAS Port A
	2	SAS Port B
	3	Tape Drive Power LED - Green

IBM LTO-6/7/8/9 Half-Height Single FC Port Drive

	1	Fibre Channel Port A
	2	Tape Drive Power LED - Green

iADT DRIVE SLEDS BACK PANEL

This section describes the elements of the iADT drive sled back panel.

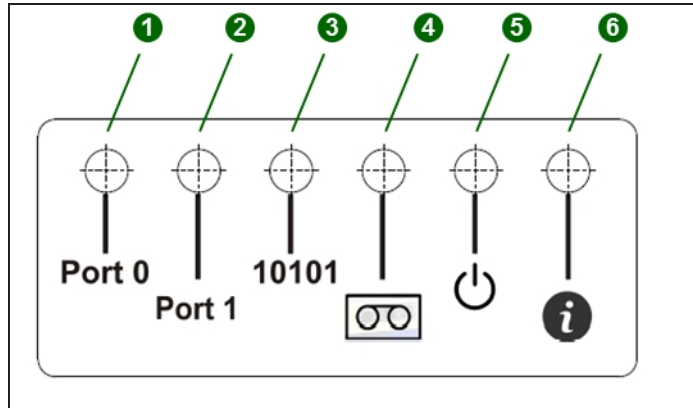
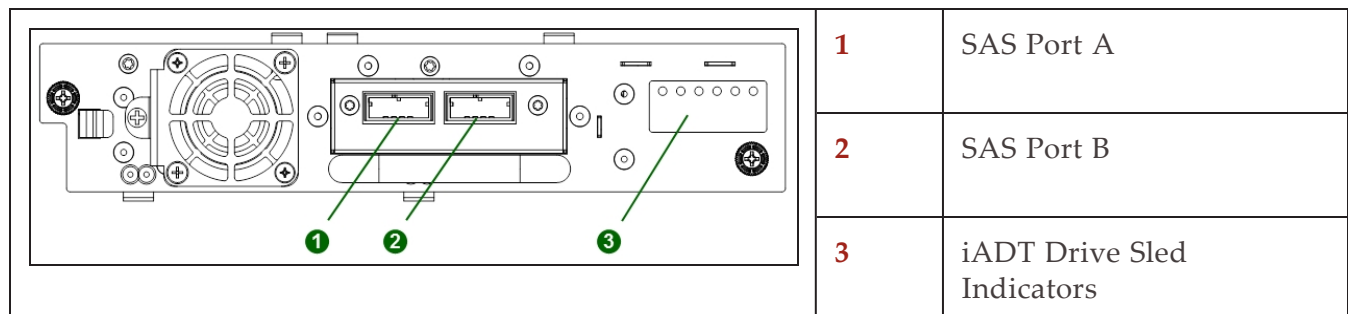

Figure 3 The iADT drive sled indicators.

Number	Indicator
1	Port A Activity
2	Port B Activity
3	Library Communication
4	Cartridge Present
5	Power
6	Beacon/UID

IBM LTO-6/7/8/9 Half-Height iADT SAS Dual Port Drive

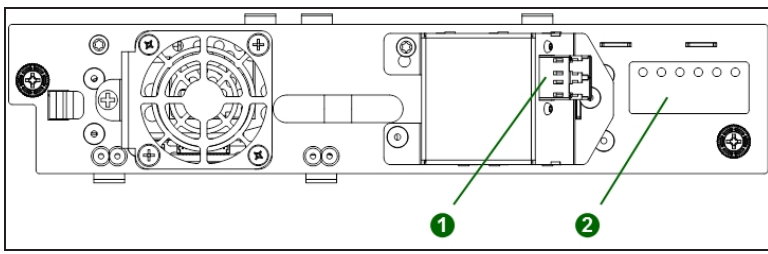

IBM LTO-6/7/8/9 Half-Height iADt Single FC Port Drive

 <p>The diagram shows the front panel of the drive. On the left is a large circular fan. In the center is a drive sled. On the right is a Fibre Channel port. Two green callout lines point to specific features: callout 1 points to the Fibre Channel port, and callout 2 points to a row of four small indicator lights on the drive sled.</p>	<p>1</p>	<p>Fibre Channel Port A</p>
<p>2</p>	<p>2</p>	<p>iADT Drive Sled Indicators</p>

POWER SUPPLY BACK PANEL

This section describes the power supply LEDs.

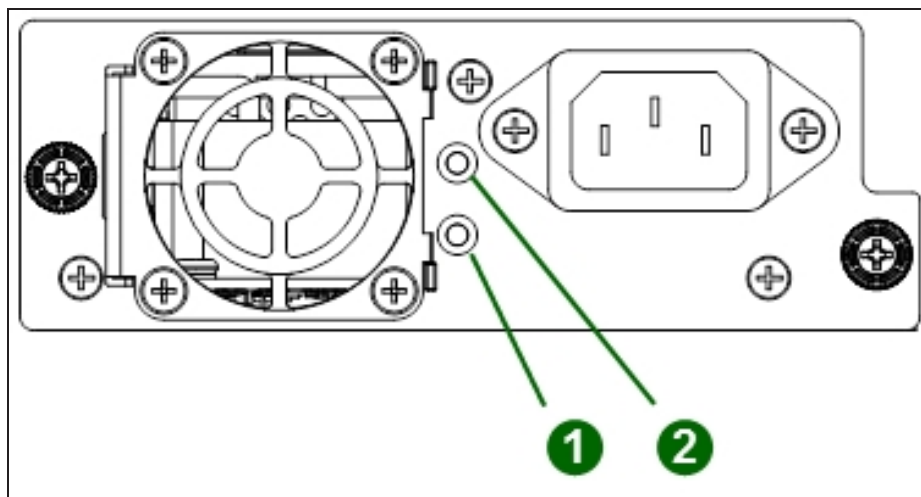

Figure 4 The library power supply LEDs.

Number	LED Color	Meaning
1	Green	Module powered on.
2	White	AC power is connected, but the library is powered off.

ELEMENT NUMBERING

The library generally displays the logical numbering of modules, storage slots, and drives, from the bottom of the library to the top.

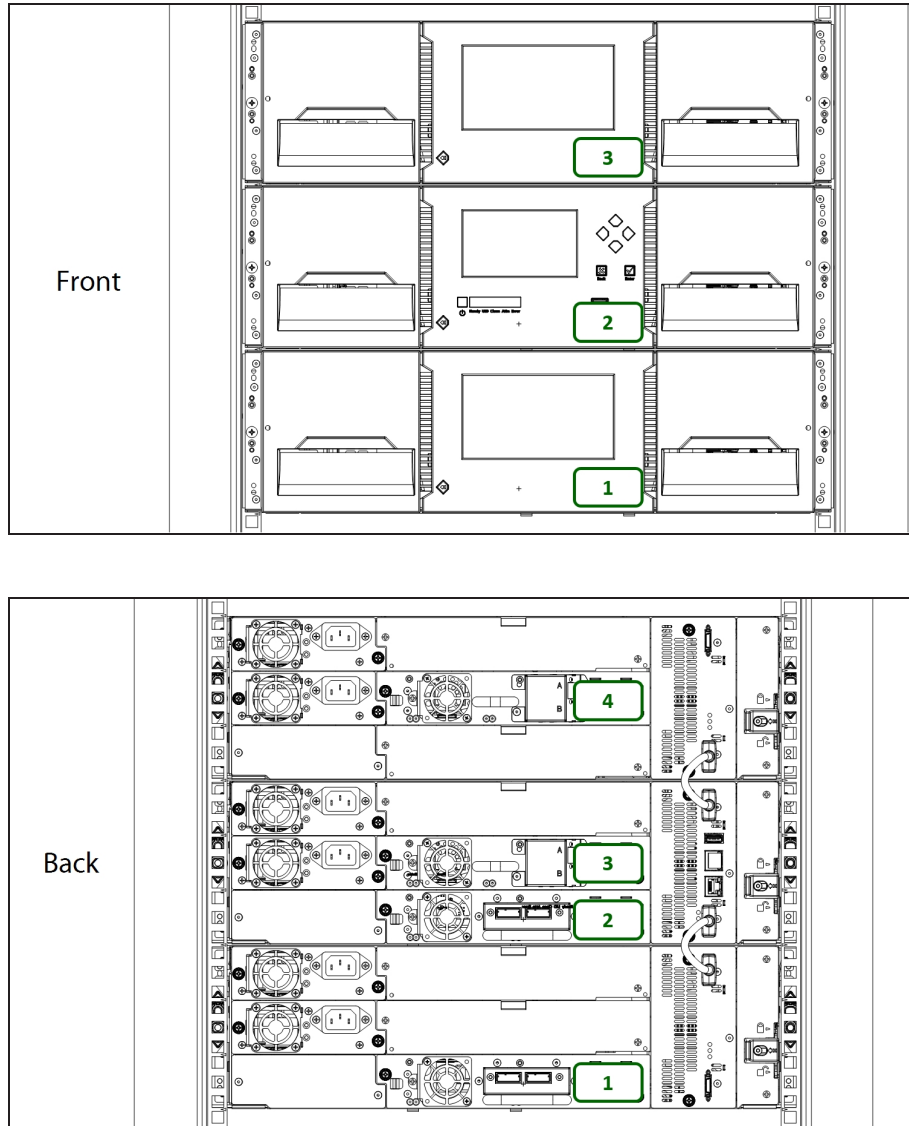

Figure 5 Example of library element numbering.

TAPE CARTRIDGES

Use the Ultrium data cartridges designed for your model of drives. All drive generation use the Ultrium universal cleaning cartridge

LTO Media Generation	Native Capacity (Compressed Capacity)
LTO-6 and LTO-6 WORM	2.5 TB (6.25 TB ^a)
LTO-7 and LTO-7 WORM	6 TB (15 TB ^b)
LTO-7 Type M	9 TB (22.5 TB ^b)
LTO-8 and LTO-8 WORM	12 TB (30 TB ^b)
LTO-9 and LTO-9 WORM	18 TB (45 TB ^b)

Note: LTO-6 and later tape drives support both rewriteable and WORM data cartridges. Write-Once, Read-Many (WORM) data cartridges provide an enhanced level of data security against accidental or malicious alteration of data on the tape cartridge. The WORM data cartridge can be appended to maximize the full capacity of the tape cartridge, but you cannot erase or overwrite data on the cartridge.

^aAssuming a 2.5:1 compression ratio. The compressed capacity depends on the type of data.

Using and Maintaining Tape Cartridges



CAUTION

Do not degauss LTO data cartridges! These data cartridges are pre-recorded with a magnetic servo signal. This signal is required to use the cartridge with LTO tape drives. Keep magnetically charged objects away from the cartridge.

To ensure the longest possible life for your data cartridges, follow these guidelines:

- Use only the data cartridges designated for your drives. See [Product Overview](#) on page 21.
- Clean the tape drive when the Clean drive LED is illuminated.
- Use only Ultrium Universal cleaning cartridges.
- Be careful not to drop a cartridge. Excessive shock can damage the internal contents of the cartridge or the cartridge case itself, making the cartridge unusable.
- Do not expose data cartridges to direct sunlight or sources of heat, including portable heaters and heating ducts.
- The recommended operating temperature range for data cartridges is 59° F to 77° F (15° C to 25° C). The storage temperature range is -40° F to 140° F (-40° C to 60° C) in a dust-free environment in which relative humidity is always between 20% and 80% (non-condensing).
- If a data cartridge is exposed to temperatures outside the specified range, acclimate the cartridge at room temperature for the same length of time it was exposed to extreme temperatures or 24 hours, whichever is less.
- Do not place data cartridges near sources of electromagnetic energy or strong magnetic fields such as computer monitors, electric motors, speakers, or X-ray equipment. Exposure to electromagnetic energy or magnetic fields can destroy data and the embedded servo code written on the media by the cartridge manufacturer, which can render the cartridge unusable.
- Place identification labels only in the designated area on the cartridge.

Labeling Tape Cartridges

The library contains a barcode reader that reads the tape labels and stores the barcode data as part of the library inventory. The library then provides the inventory information to the host application, OCP, and RMI. Having a barcode label on each tape cartridge enables the barcode reader to identify the cartridge quickly, thereby speeding up inventory time.



IMPORTANT

The tape library does not support unlabeled media. Make sure every cartridge has a barcode label in place.



IMPORTANT

All barcode labels must be either checksummed or non-checksummed. You cannot mix the two types in the library.

A proper barcode label includes the media identifier in the last two characters of the barcode. The library will not load an incompatible cartridge, based on the barcode media identifier, into a tape drive. For example, the library will not load a cartridge labeled as LTO-3 into an LTO-6 tape drive. This saves the time needed to load the cartridge and have the tape drive reject it.

Note: Though not recommended, disabling barcode checking in the **Configuration > Ignore Barcode Media ID** screen allows all media moves regardless of the barcode media identifier.

Your host software may need to keep track of the following information via the associated barcode:

- Date of format or initialization
- Tape's media pool
- Data residing on the tape
- Age of the backup
- Errors encountered while using the tape (to determine if the tape is faulty)



IMPORTANT

Misusing and misunderstanding barcode technology can result in backup and restore failures. Use only high quality labels. Self-printed labels are not recommended as they are often a source of barcode reading issues.



IMPORTANT

The barcode label should only be applied as shown, with the alphanumeric portion facing the hub side of the tape cartridge. Never apply multiple labels onto a cartridge because extra labels can cause the cartridge to jam in a tape drive.

LTO tape cartridges have a recessed area located on the face of the cartridge next to the write-protect switch. Use this area for attaching the adhesive-backed barcode label. Only apply labels as shown:

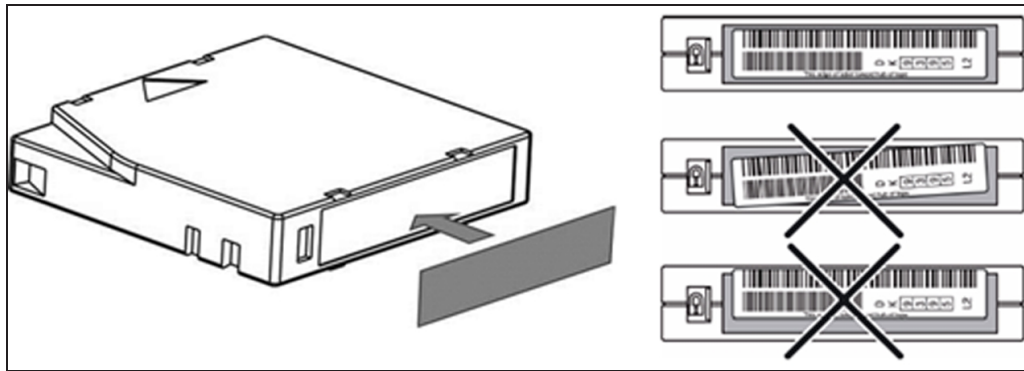

Figure 6 Tape cartridge barcode location.

Note: For detailed information on tape barcode specifications, see [Specifications](#) on page 196.

Write Protecting Tape Cartridges

All rewriteable data cartridges have a write-protect switch to prevent accidental erasure or overwriting of data. Before loading a cartridge into the library, make sure the write-protect switch on the front of the cartridge is in the desired position.

- Slide the switch to the left to allow the drives to write data to the cartridge.
- Slide the switch to the right to write-protect the cartridge. An indicator, such as a red mark or small padlock, is visible showing that the cartridge is write-protected.

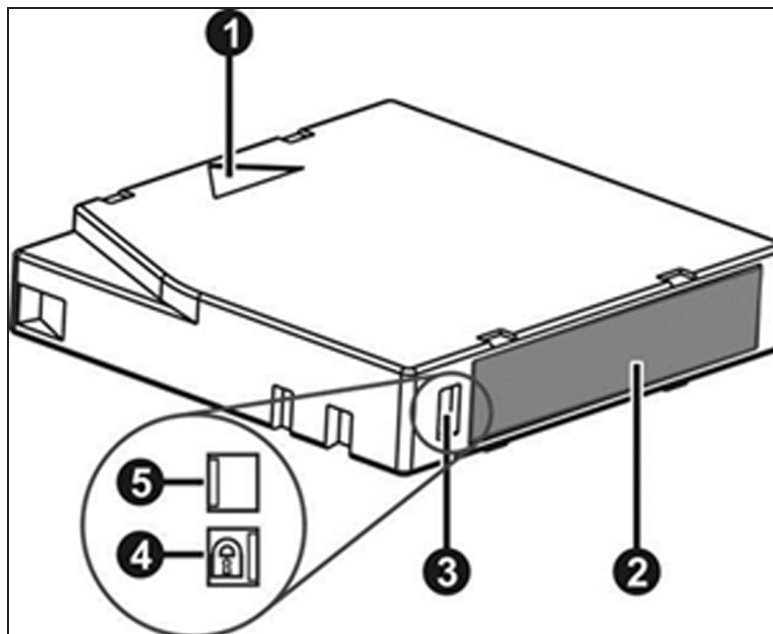

Figure 7 Tape cartridge features.

Callout	Feature
1	Insertion Arrow
2	Barcode Label
3	Write-Protect Switch
4	Write-Protected
5	Write-Enabled

Read and Write Compatibility

Key:

- **R/W** = Read/Write
- **RO** = Read Only

Drive Gen	LTO-5 Media	LTO-6 Media	LTO-7 Media	M8 Media	LTO-8 Media	LTO-9 Media
LTO-6	R/W	R/W	Not supported	Not supported	Not supported	Not supported
LTO-7	<i>RO</i>	R/W	R/W	Not supported	Not supported	Not supported
LTO-8	Not supported	Not supported	R/W	R/W	R/W	Not supported
LTO-9	Not supported	Not supported	Not supported	Not supported	R/W	R/W

INTEGRATION WITH A BLACKPEARL SYSTEM

Spectra SL3 libraries can be used with BlackPearl systems running BlackPearl OS 5.8, or later. For information on using a SL3 library in a BlackPearl system, see the [Spectra BlackPearl User Guide](#).

CHAPTER 2 - USING THE BLUEVISION INTERFACE

This chapter provides information on using the BlueVision interface.

Using the Operator Control Panel	38
Using the Remote Management Interface	39
Library User Types	40
Logging into the Library	41
Using the Library Main Screen	42
Top Banner Elements	43
Left Pane Elements	44
Right Pane Elements	46
Center Pane Elements	46

The library provides two main interfaces:

- **Operator Control Panel (OCP)** - With the OCP, you can monitor, configure, and control the library from the LCD screen on the controller module.
- **Remote Management Interface (RMI)** - With the RMI, you can monitor, configure, and control the library from a web browser. The RMI hosts a dedicated, protected website that displays a graphical representation of the library.

The OCP and RMI are similar in design and functionality.

Before using the RMI, you must configure the library network settings and set the administrator password with the OCP. This is typically done using the Initial Configuration Wizard, see [Configuring the Library](#) on page 48.

When possible, it is recommended that the RMI be used as the primary library interface because the web interface provides access to additional features, such as configuring SNMP, IPv6, encryption, and partitions, includes online help, and is easier to use.

USING THE OPERATOR CONTROL PANEL

The OCP has a power button, an LCD touch screen, five indicator LEDs, and a USB port. With the OCP you can monitor, configure, and operate most library functions from the library LCD screen on the controller module. To navigate the OCP, click on the LCD touch screen.

Front Panel LED Indicators

Indicator	Meaning
Module ID	Blue when activated. The unit identification (UID) LEDs are controlled by the user through the OCP and RMI Maintenance > UID LED Control screen. The UIDs on the OCP and back panel UID are activated and deactivated together. The UIDs are helpful for locating the library in a data center.
Ready	Steady green when the library is on, and blinking green when there is library robotic assembly activity.
Clean	Amber when a tape drive requires cleaning.
Attention	Amber blinking if the library detects a condition for which user attention is necessary, but which does not prevent the library from performing most operations.
Error	Amber if an unrecoverable tape drive or library error occurs. A corresponding error message displays on the LCD screen. User intervention is required; the library is not capable of performing some operations.

USING THE REMOTE MANAGEMENT INTERFACE

With the RMI, you can monitor, configure, and operate most library functions from a web browser.

To start the RMI, open the latest version of a supported HTML browser and enter the IP address of the library in the browser's address bar. Supported browsers include Internet Explorer, Firefox, Chrome, and Safari.



IMPORTANT

Check the online help in the RMI for additional information. The help pages are updated with firmware updates and often contain up-to-date technical details that might not be contained in this document. To access RMI help, click the ? icon on the right side of the RMI top banner.

LIBRARY USER TYPES

The library offers four types of user, each with different levels of access to library functions.

- **Administrator** – The administrator user has access to all functionality except for the log configuration, service features, and encryption features.

**IMPORTANT**

By default, the administrator password is not set. You must set the administrator password from the OCP (see [Configuring the Library on page 48](#)) before you can access the administrator functions on the RMI.

-
- **User** – The user account provides access to status information, but not configuration, maintenance, or operation functions.

**IMPORTANT**

By default, the user password is not set.

-
- **Service** – This user is for use by service personnel only. The service password is set at the factory. To access the service features of the library, both the administrator and service passwords must be entered.
 - **Security** - The security user has access to all administrator functionality and can also configure security features and change the security user password.

**IMPORTANT**

By default, the security password is set to `security`. You must change the security password from the OCP before the account can be used from the RMI (see [Configuring the Library on page 48](#)).

LOGGING INTO THE LIBRARY

Use the instructions in this section to log into the library. The process is similar when using either the OPC or RMI.

1. Access the user interface:
 - **Using the OCP** - touch the screen to clear the screen saver and display the login screen.
 - **Using the RMI** - open a web browser and enter the IP address of the library in the browser address bar.

The Login screen displays.

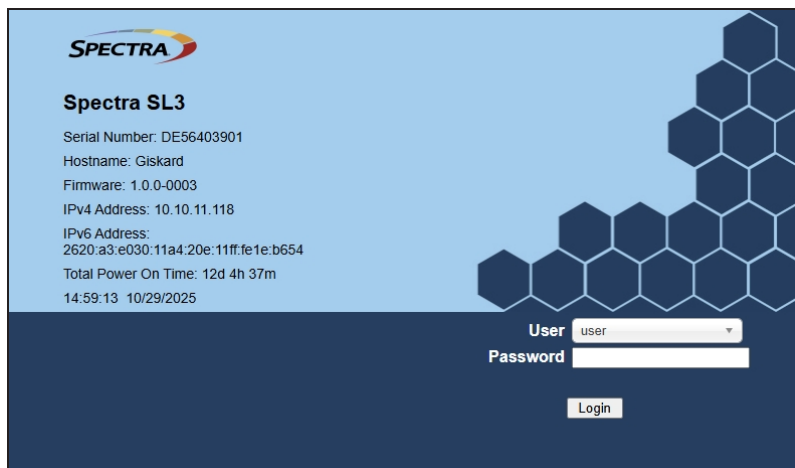

Figure 8 The Login screen.

2. Using the drop-down menu, select the desired **User**.
3. If necessary, enter the **Password** for the user.
4. Click **Login**.
5. If the user has two-factor authentication enabled, enter the **TOTP** (Time-Based One-Time Password) six digit code from the authenticator application on your host computer or phone, then click **Login**.

USING THE LIBRARY MAIN SCREEN

The library main screen is organized into the following regions:

- **Top Banner** - Contains the home button and displays the overall library status and information about the library and the current user. See [Using the BlueVision Interface on page 37](#).
- **Left Pane** - Displays the library identity and all module statuses. See [Using the BlueVision Interface on page 37](#).
- **Right Pane** - (RMI only) Displays a log of recent events or a navigation menu after clicking one of the center buttons. See [Using the BlueVision Interface on page 37](#).
- **Center Pane** - Provides access to operate and configure the library, and to view additional status information. See [Using the BlueVision Interface on page 37](#).

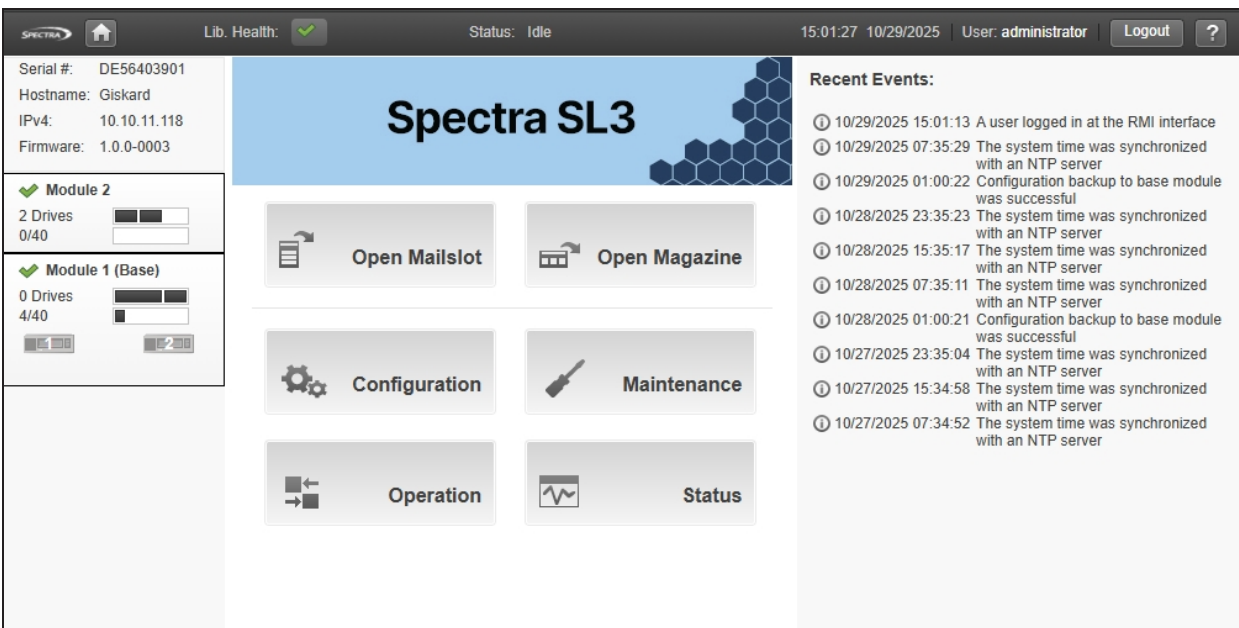





Figure 9 Spectra SL3 main screen.

Top Banner Elements



Figure 10 The BlueVision top banner.

Icon	Meaning
Home Icon	Returns to the library main screen.
Library Health	<p>An icon indicating the overall health status of the library.</p> <p> OK - The green check mark icon indicates the library is fully operational.</p> <p> Warning - The yellow exclamation point icon indicates that user attention is necessary, but the library can continue most operations.</p> <p> Error - The red X icon indicates that the library experienced an error that prevents it from continuing normal operations, and user intervention is required.</p>
Status	<p>The status of the library robotics:</p> <ul style="list-style-type: none"> • Idle - The library robotics is ready to perform an action. • Moving - The library robotics is moving a cartridge. • Scanning - The library robotics is performing an inventory of cartridges. • Offline - The library robotic assembly has been taken offline by the library.
Library Time & Date	Helpful when analyzing event logs and support tickets, and might be needed when contacting support.
User	The user account for this session.
Logout	Logs out of this session.
?	Accesses online help. When using RMI, you can search the online help for a specific term by pressing CTRL+F on the keyboard.

Left Pane Elements

The left pane displays general library information and module status information.

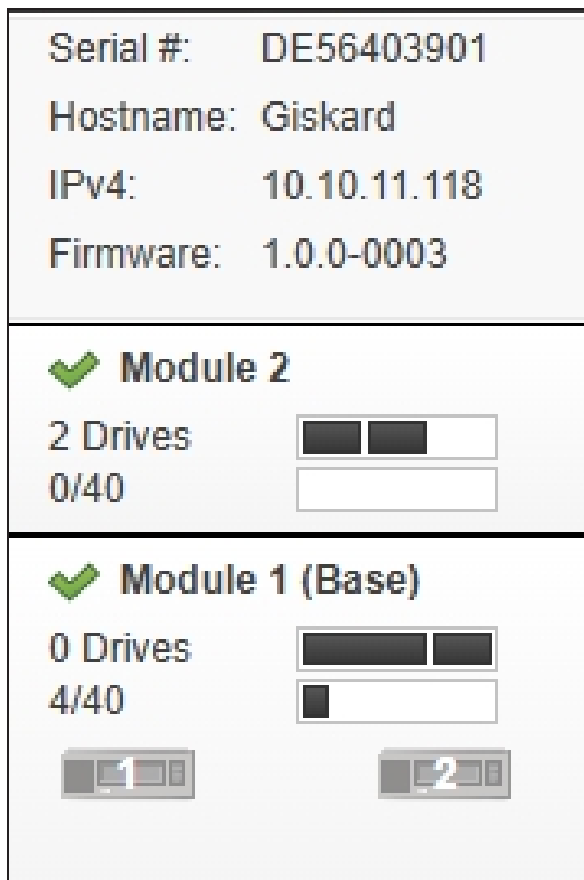





Figure 11 The BlueVision left pane.

Library Information

Parameter	Meaning
Serial #	The controller module serial number.
Hostname	The library hostname.
Network Configuration	The internet protocol version (IPv4, IPv6, or both) and IP address.
Firmware	The current library firmware version.

Module Status Overview

The module status overview provides a summary of each module's configuration and health. Selecting a module displays additional information.

Parameter	Meaning
Module Health Icon	 OK - The green check mark icon indicates the library is fully operational.  Warning - The yellow exclamation point icon indicates that user attention is necessary, but the library can continue most operations.  Error - The red X icon indicates that the library experienced an error that prevents it from continuing normal operations, and user intervention is required.
Module Number	Modules are numbered based on their location in the physical library. The bottom module is Module 1. The controller module is annotated with "(Base)".
Drive Status	<p>The number of drives installed in the module and the health of each drive. Click the drive to display drive configuration and status information in the center pane.</p> <ul style="list-style-type: none"> • A black square indicates that the drive is fully operational and that no user intervention is required. • A yellow square indicates that user attention is necessary, but that the drive can still perform most operations. • A red square indicates that user intervention is required or the drive is not capable of performing some operations.
Magazine Slot Usage	The number of cartridge slots used and the number available formatted as <i>xx/yy</i> where <i>xx</i> = slots used and <i>yy</i> =slots available.
Drive Operation Status	<p>The current drive activity for each drive in the module. The drive operation status is only displayed for the selected module.</p> <ul style="list-style-type: none"> • Write - The drive is performing a write operation. • Read - The drive is performing a read operation. • Idle - A tape cartridge is in the drive but the drive is not performing an operation. • Empty - The drive is empty. • Encryp - The drive is configured to read and write encrypted data.

Right Pane Elements

The right pane displays a log of recent events or a navigation menu after clicking one of the center buttons described in [Using the BlueVision Interface](#) on page 37.

Center Pane Elements



Figure 12 The BlueVision home page center pane.

Selection	Meaning
Open EE Port (Administrator or Security user only)	Click to access the Operations > Open EE Port screen to see the status of EE port(s) and select an EE port to open. EE ports must be enabled before the slots can be used as EE ports. See Configuring the Library on page 48.
Open Magazine (Administrator or Security user only)	Click to access the Operation > Open Magazine screen to select a magazine to open. Only one magazine in the library can be open at a time. See Operating the Library on page 100.
Configuration (Administrator or Security user only)	Click to configure the library system, network, drives, EE ports, partitions, encryption, user accounts, and web management settings. See Configuring the Library on page 48.

Selection	Meaning
Maintenance (Administrator or Security user only)	Click to access maintenance functions including running system tests, collecting logs and traces, upgrading software, downloading drive logs, rebooting the system, rebooting drives, controlling the UID LEDs, and moving the robotic assembly to the control module. See Maintaining the Library on page 127 .
Operation (Administrator or Security user only)	Click to access operation functions including moving media, cleaning drives, rescanning inventory, and forcing drive media ejection. See Operating the Library on page 100 .
Status	Click to access cartridge inventory and status information.

CHAPTER 3 - CONFIGURING THE LIBRARY

This chapter contains instructions for configuring the Spectra SL3 library. Before using this chapter, install the library using the *Spectra SL3 Library Installation Guide*.

Using the Initial Configuration Wizard	50
Saving, Restoring, and Resetting the Library Configuration	51
Saving the Library Configuration	52
Verify the Configuration Backup File	52
Resetting to the Default Settings	54
Configuring the Date and Time Format	55
Setting the Time Zone	56
Setting the Date and Time Format	57
Setting the Date and Time	57
Enabling SNTP (Simple Network Time Protocol) Synchronization	58
Configuring Media Barcode Compatibility Checking	59
Add a License Key	60
Configuring the Library Network Settings	61
Reset the Internal IP Range	63
Configuring SNMP	65
Configuring Event Notification Parameters	68
Configuring Tape Drives	70
Enabling or Disabling Mailslots	72
Configuring Library Partitions	73
Using the Basic Partition Wizard	73
Using the Expert Partition Wizard	76
Configure Encryption	78
KMIP Wizard	78
Configure User Accounts	84
Configure User Account Settings	84
Configure Local User Accounts	86
Configure LDAP	91
Web Management	95
Security Certificates	95

Session Timeout	98
OCP/RMI Session Locking	98
Restrict RMI Access	99

USING THE INITIAL CONFIGURATION WIZARD

The Initial Configuration Wizard guides you through setting the administrator password, configuring the time zone, date and time, and library network settings, and then starting an initial system test. You can skip items and stop the wizard at any time. Once you have configured the network settings and set the administrator password from the OCP, you can initiate the wizard from the RMI or use the OCP to complete the remaining configurations.

SAVING, RESTORING, AND RESETTING THE LIBRARY CONFIGURATION

You can save the library configuration settings to a file, restore the settings, or reset the library configuration to the default settings from the **Configuration > System > Save/Restore Configuration** screen. The saved configuration database makes it easier to recover the library configuration if you need to replace the controller module or the controller in the controller module.

Configuration > System > Save/Restore Configuration

▲ Save Configuration File

Save ...

▲ Restore Configuration File

Configuration File: Choose File No file chosen

▲ Reset Default Settings

Reset Default Settings ...

▲ Reset the List of Known Drives and Modules

NOTE: Resetting the list of known drives and modules will cause the library to re-discover only the drives and modules that are physically present. This operation will alter the list of element addresses reported to hosts and will re-number the drives and modules. This operation cannot be undone. After the operation completes, use one of the partition wizards to modify partitioning as needed.

Reset

▲ Reset Hardware Configuration

NOTE: Resetting the Hardware Configuration will cause the library to re-discover the currently present hardware. This operation cannot be undone. After the operation completes, use one of the partition wizards to modify partitioning as needed.

Reset

▲ Save MLM Database

Save ...

▲ Restore MLM Database

Backup File: Choose File No file chosen

Figure 13 The Save/Restore System Configuration screen.



IMPORTANT

The backup configuration can only be used to restore the library that generated the backup. The configuration is tied to the Hardware ID of the library and cannot be transferred to another library.

The library configuration backup can be generated using the library operator control panel to save the file to a USB device, or using the RMI to download the backup file.

The following settings are not saved in the backup configuration file:

- The administrator password

- Date and time
- Library hostname
- KMIP certificates
- License keys
- Library MAC address
- Library, controller, and chassis serial numbers
- Robot calibration data
- Operator control panel calibration data
- Library hardware configuration

Note: If you have previously saved a configuration backup file and want to use the file to restore the library configuration, see [Configuring the Library](#) on page 48.

Saving the Library Configuration

1. Login to the library as a user with administrator privileges.
2. Navigate to the **Configuration > System > Save/Restore Configuration** screen as shown [Chapter 3](#).
3. If necessary, click **Save Configuration File** to expand the section.
4. If you are using the OCP, insert a USB device into one of the USB ports on the controller module.
5. Click **Save**.

Note: It takes approximately three minutes for the library to display **Download** and **Cancel** buttons.

The destination location depends on how you are accessing the library:

- **RMI** — (RMI only) Downloads the configuration file through the browser to the system running the RMI.
- **USB Device** — (OCP only) Downloads the configuration file to a USB device inserted into the USB port on the front or the back of the library.

6. Click **Download**.

Verify the Configuration Backup File

After creating a backup of your library configuration, use one of the methods described in the following sections to verify that the backup was successful as soon as possible after you create it.

When Saved to a USB Device

1. Plug the USB device into a USB port on a host computer.

2. Examine the list of files on the USB device and locate the ZIP file containing the system configuration backup. The file is named: *syslog-LibraryName-PackageLevel-Timestamp.ZIP*.
3. Open the ZIP file and confirm the file “details.bin” is present and greater than 0 bytes.

Note: The ZIP file also contains text files of different library messages. If no messages of a given type are present in the library, the log for that message type is 0 bytes.

When Saved to a Host Computer

1. Locate the ZIP file containing the system configuration backup. The file is named: *syslog-LibraryName-PackageLevel-Timestamp.ZIP*.

2. Open the ZIP file and confirm the file “details.bin” is present and greater than 0 bytes.

Note: The ZIP file also contains text files of different library messages. If no messages of a given type are present in the library, the log for that message type is 0 byte

Restoring the Library Configuration

Note: Restoring the configuration from a saved configuration file restores passwords for the users with security and user roles, but does not restore an administrator user password.

1. Login to the library as a user with administrator privileges.
2. Navigate to the **Configuration > System > Save/Restore Configuration** screen.
3. If necessary, click **Restore Configuration File** to expand the section.
4. If you are using the OCP to restore the configuration file from a USB device, copy the configuration file you want to restore onto the USB device and remove any other configuration files from the USB device.

Note: If multiple library configuration backups are present on the USB device, the library uses the most recent backup to restore the configuration.

Insert the USB device containing the configuration file into one of the USB ports on the controller module.

5. Select the source location:
 - **RMI** — (RMI only) Restores the configuration file from the computer running the RMI. Select **Choose File** and use your web browser to select the configuration file you want to restore.
 - **USB Device** — (OCP only) Restores the configuration file from a USB device inserted into the USB port on the front or the back of the library.
6. Click **Upload File & Restore**. The library reboots to restore the configuration.

Resetting to the Default Settings

To reset the library configuration to the default settings, you must be logged in as the Administrator or Security user.

1. Log in as the security user.
2. Navigate to the **Configuration > System > Save/Restore Configuration** screen shown above.
3. If necessary, click **Reset Default Settings** to expand the section.
4. Click **Reset Default Settings**.

For the detailed listing of the default settings, see [Specifications](#) on page 196.

CONFIGURING THE DATE AND TIME FORMAT

You can configure the date and time format, the current date and time, and an SNTP server from the **Configuration > System > Date and Time Format** screen.

Note: The library does not adjust its time for daylight savings; the time must be adjusted manually.

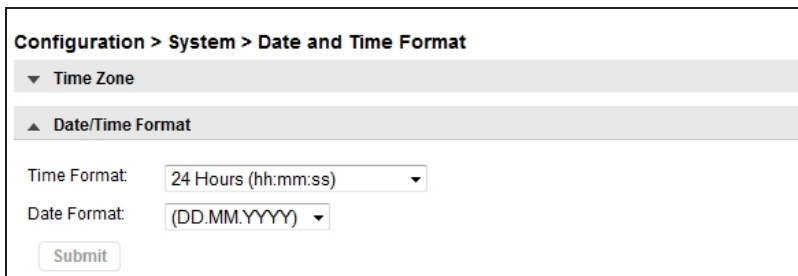

The screenshot displays the configuration interface for the Date and Time Format. At the top, the breadcrumb path is 'Configuration > System > Date and Time Format'. Below this, there are two main sections: 'Time Zone' (collapsed) and 'Date/Time Format' (expanded). Under 'Date/Time Format', there are two dropdown menus: 'Time Format' is set to '24 Hours (hh:mm:ss)' and 'Date Format' is set to '(DD.MM.YYYY)'. A 'Submit' button is located at the bottom of the form.

Figure 14 The Date and Time Format screen.

Setting the Time Zone

1. On the Date and Time Format screen, if necessary, click **Time Zone** to expand the section.

A list of continents, countries, and regions is displayed. When an item preceded with '>', for example '>US', is selected, a submenu is displayed in the next column.

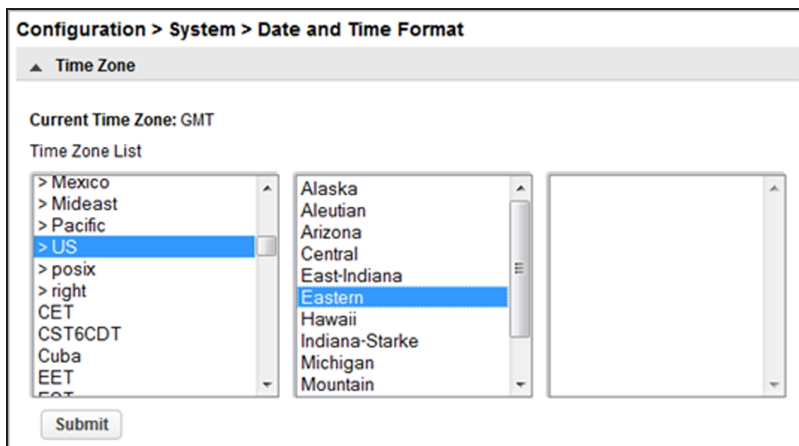

Figure 15 Select the time zone.

2. Expand the time zone list, as necessary, until a location with the appropriate time zone is visible.
3. Select a location with the appropriate time zone.
4. Click **Submit**.

Setting the Date and Time Format

1. On the Date and Time Format screen, if necessary, click **Date/Time Format** to expand the section.

Configuration > System > Date and Time Format

▼ Time Zone

▲ Date/Time Format

Time Format: 24 Hours (hh:mm:ss) ▼

Date Format: (YYYY-MM-DD) ▼

Submit

▼ Set Date/Time

▼ SNTP

Figure 16 Select the date and time format.

2. Select a **Time Format** (12 Hours or 24 Hours).
3. Select a **Date Format**:

For example, February 28, 2018 is displayed as:

- DD.MM.YYYY - 28.02.2018
- MM/DD/YYYY - 02/28/2018
- YYYY-MM-DD - 2018-02-28

4. Click **Submit**.

Setting the Date and Time

1. On the Date and Time Format screen, if necessary, click **Set Date/Time** to expand the section.

Configuration > System > Date and Time Format

▼ Time Zone

▼ Date/Time Format

▲ Set Date/Time

Time: 15:26:34 24 Hours (hh:mm:ss)

Date: 14.04.2014 (DD.MM.YYYY)

Submit Now

Figure 17 Set the date and time.

2. Set the time and date.

To set the time and date manually:

- a. Enter the time in the configured time format.
- b. Enter the date or select it from the calendar.

To synchronize the time and date with the computer running the browser, click **Now**.

3. Click **Submit**.

Enabling SNTP (Simple Network Time Protocol) Synchronization

To enable SNTP, the library must have network access to an SNTP server.

Note: If you plan to enable two-factor authentication for a user(s), you must enable SNTP before you can use two-factor authentication.

1. On the Date and Time Format screen, if necessary, click **SNTP** to expand the section.

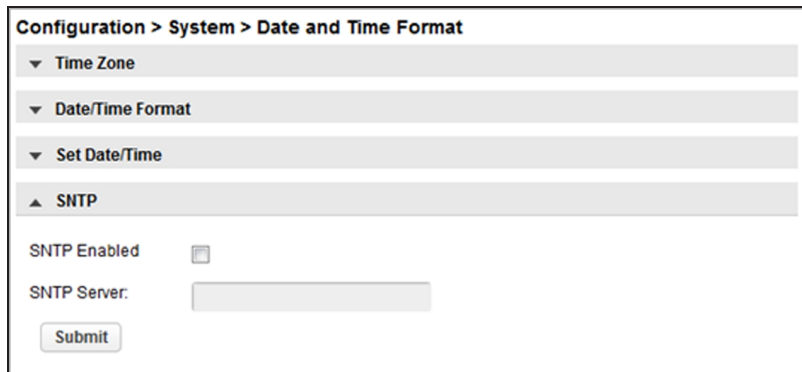

The screenshot shows a web interface for configuring system settings. The breadcrumb trail is "Configuration > System > Date and Time Format". There are four expandable sections: "Time Zone", "Date/Time Format", "Set Date/Time", and "SNTP". The "SNTP" section is expanded, showing a "SNTP Enabled" checkbox (which is currently unchecked), a "SNTP Server:" label followed by an empty text input field, and a "Submit" button at the bottom.

Figure 18 Enable SNTP.

2. Select the **SNTP Enabled** check box.
3. Enter the **SNTP Server** address.
4. Click **Submit**.

CONFIGURING MEDIA BARCODE COMPATIBILITY CHECKING

The barcode media identifier is the last two characters of the barcode. The library uses the media identifier to verify the media is compatible with the tape drives installed. If the last two characters of the barcode do not match to any known identifier, then barcode is non-standard, and the barcode compatibility check is not possible.

When **Barcode Media ID Restriction** is enabled, the library fails a move of an incompatible tape cartridge into a tape drive. It is enabled by default. For example, an LTO-8 labeled cartridge is not allowed to move into an LTO-6 tape drive. Unknown media is treated as compatible by the library.

When **Barcode Media ID Restriction** is disabled, the library does not check the compatibility of a tape cartridge with the tape drives before moving it. If the cartridge is incompatible with the tape drive, the drive generates an error.

Note: It is strongly recommended that all cartridges have barcode labels with the correct media identifier, and that the **Barcode Media ID Restriction** is enabled.

On the **Configuration > System > Media Barcode Compatibility Check** screen, select or clear the **Barcode Media ID Restriction** and click **Submit**.

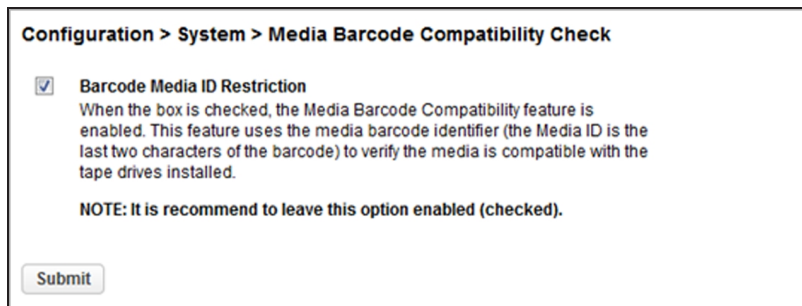

The screenshot shows a configuration window titled "Configuration > System > Media Barcode Compatibility Check". It contains a checked checkbox for "Barcode Media ID Restriction". Below the checkbox is a descriptive paragraph: "When the box is checked, the Media Barcode Compatibility feature is enabled. This feature uses the media barcode identifier (the Media ID is the last two characters of the barcode) to verify the media is compatible with the tape drives installed." Below this is a note: "NOTE: It is recommend to leave this option enabled (checked)." At the bottom left of the window is a "Submit" button.

Figure 19 The Media Barcode Compatibility Check screen.

ADD A LICENSE KEY

1. To add a license key, navigate to the **Configuration > System > License Key Handling** screen.

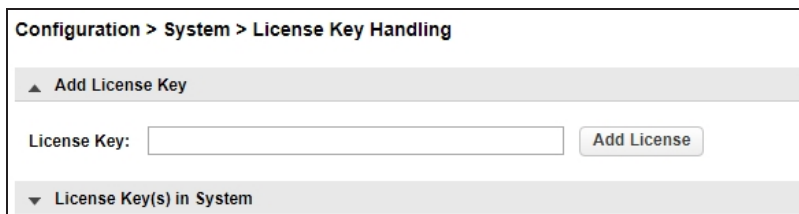

The screenshot shows a web interface for 'License Key Handling'. At the top, it displays the breadcrumb 'Configuration > System > License Key Handling'. Below this, there is a section titled 'Add License Key' with an upward-pointing triangle icon. Underneath, there is a label 'License Key:' followed by a text input field and an 'Add License' button. At the bottom of the section, there is a section titled 'License Key(s) in System' with a downward-pointing triangle icon.

Figure 20 The License Key Handling screen.

2. If necessary, click **Add License Key** to expand the section.
3. Enter the license key. The license key needs to have a length of 15 characters.
4. Click **Add License**.

Note: The button for deleting license key(s) is only available with the Service login.

CONFIGURING THE LIBRARY NETWORK SETTINGS

You can configure the library network settings from the **Configuration > Network** screen.

The screenshot shows the 'Configuration > Network' interface. At the top, there are fields for 'Host Name' and 'Domain Name', both with placeholder text. Below these is a 'Protocol' dropdown menu set to 'IPv4 & IPv6'. The interface is divided into two main sections: 'IPv4' and 'IPv6'. The 'IPv4' section has a 'Method' dropdown set to 'DHCP' and input fields for 'Address', 'Netmask', 'Gateway', 'DNS 1', and 'DNS 2'. The 'IPv6' section has a 'Method' dropdown set to 'Static', a 'Current Address' field with the value 'fd01::20e:11ff:fe80:3de3', and input fields for 'Address', 'Prefix Length', 'Gateway', 'DNS 1', and 'DNS 2'. At the bottom of the IPv6 section, there are 'Submit' and 'Undo' buttons. Below the IPv6 section is a section titled 'Reset internal IP Range (in case of conflict)' with a red note: 'NOTE: Only reset the internal IP range if you are using the same range in your network environment.' Below this note is a 'Current internal IP Range' field and a 'Submit' button.

Figure 21 The Configuration > Network screen.

Note: It may be helpful to have your System Administrator assist you in configuring the network settings.

1. If desired, enter a new **Host Name**.
2. If desired, enter a **Domain Name**.

3. Using the **Protocol** drop-down menu, select IPv4, IPv6, or both.
 - If you selected IPv4 or IPv4 & IPv6:
 - i. If necessary, click **IPv4** to expand the section.
 - ii. Using the **Method** drop-down menu, select either DHCP or Static addressing.
 - iii. If you are configuring a static IP address, enter the **Address**, **Netmask**, and **Gateway** addresses.
 - iv. If desired, enter **DNS** server information.
 - If you selected IPv6 or IPv4 & IPv6:
 - i. If necessary, click **IPv6** to expand the section.
 - ii. Using the Method drop-down menu, select Static or Stateless.
 - iii. If you are configuring a static IP address, enter the **Address**, **Prefix Length**, and **Gateway**.
 - iv. If desired, enter **DNS** server information.
4. Click **Submit**.

**IMPORTANT**

To view the network settings set using the DHCP or Stateless method, use the OCP and see [Viewing Library Status on page 108](#).

Note: If you are using the RMI to access the Spectra SL3 library and you have changed the IP address, you lose your connection to the user interface when you click **Submit**. To re-establish the connection, enter the new IP address in your browser and log in again.

RESET THE INTERNAL IP RANGE

For internal communication between modules, the tape library uses an Ethernet connection with an internal IP address range. To prevent any conflict between the internal IP address range and the external IP addresses, it is required to select the internal IP range before the tape library connects to the external Ethernet network.

Use the following instructions if you need to change the internal IP range after its initial configuration during the library installation:

1. Navigate to the **Configuration > Network** screen.
2. If necessary, click **Reset Internal IP Range (in case of conflict)** to expand the section and then click **Submit**. The library reboots. When the library completes its initialization, the Internal and External IP Conflict Prevention screen displays on the OCP.

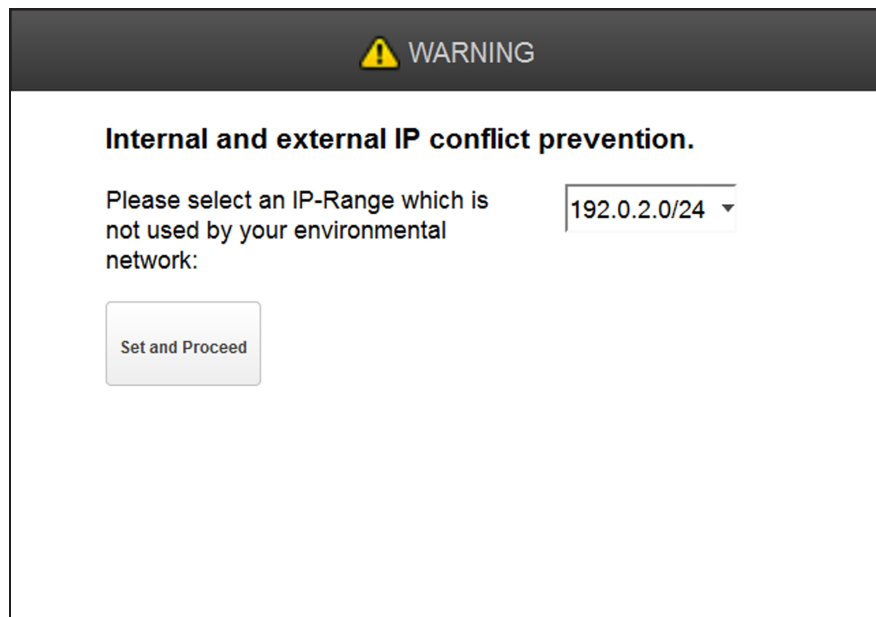

WARNING

Internal and external IP conflict prevention.

Please select an IP-Range which is not used by your environmental network:

Figure 22 The IP Conflict Prevention Screen.

- Using the drop-down menu, select one of the three default IP address ranges that is not used by your external network.

Note: If none of the three pre-entered address ranges is suitable for use in your network, contact Spectra Logic Technical Support.

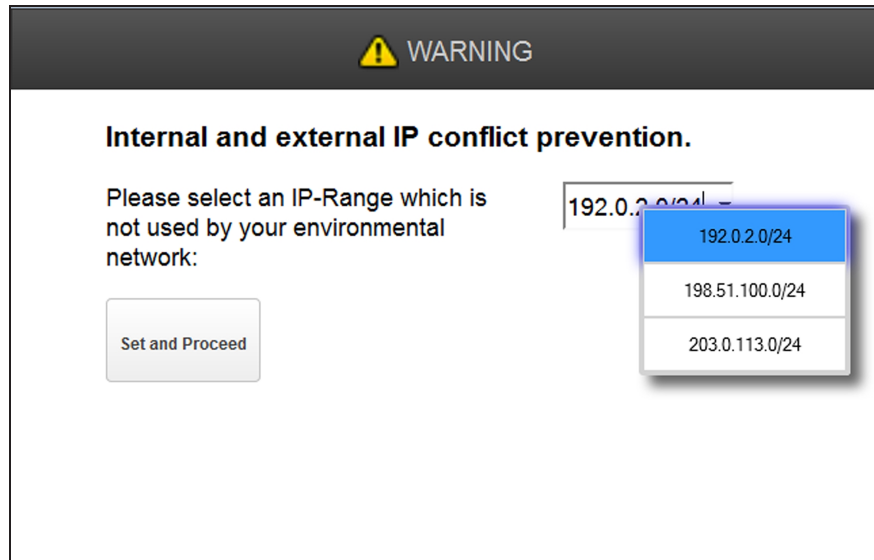

Figure 23 Select an IP address range using the drop-down menu.

- Click **Set and Proceed**. The library reboots and displays the login screen (see Chapter 2 on page 37).

CONFIGURING SNMP

Use the **Configuration > Network Management** screen to enable and configure SNMP (Simple Network Management Protocol), which allows applications to monitor the library. The library supports both SNMP configuration and SNMP traps.

Configuration > Network Management > SNMP

SNMP Enabled: [Download MIB File](#)

Community Name:

Notification Level:

SNMP Targets

IP/Hostname	Port	Version	Community	Action
	162	SNMPv1	public	Edit Delete

The configuration options below are only needed when using SNMPv3.

Limit all library SNMP communication to SNMPv3:

SNMPv3 Security Level:

Authentication User Name:

Authentication Password:

NOTE: Needed for security levels authNoPriv and authPriv (8 -31 characters)

Authentication Protocol:

NOTE: Needed for security levels authNoPriv and authPriv

Privacy/Encryption Protocol:

NOTE: Needed for security level authPriv

Privacy/Encryption Passphrase:

NOTE: Needed for security level authPriv (8 -31 characters)

[Submit](#) [Clear SNMPv3 Options](#)

Figure 24 The SNMP screen.

1. Select the **SNMP Enabled** check box to enable SNMP. When selected, the configuration entry fields become accessible.
2. In the **Community Name** text box, enter a string used to match the SNMP management station and the library. Both the management station and the library must use the same Community Name. The default community name is `public`.
3. Use the drop-down menu to select the **Notification Level**.
4. The SNMP Targets pane lists all configured SNMP targets.

To add or edit an SNMP target:

- a. Click **Edit** for the appropriate SNMP target. To add a new SNMP target, click **Edit** on the row with a blank IP/Hostname.
- b. Enter the required information:

Field	Description
IP/Hostname	The target IP address or hostname.
Port	The port on which to communicate with the SNMP target. The default is 162.
Version	The SNMP version supported by the SNMP target.
Community	The SNMP community string for the target.

- c. Click **Submit**.

To delete an SNMP target:

- a. Click **Delete** next to the target to be deleted.
- b. Click **Submit**.

5. If any targets use SNMP version SNMPv3, enter the SNMPv3 configuration options and click **Submit**.

Field	Description
SNMPv3 Security Levels	<ul style="list-style-type: none"> • noAuthnoPriv — Permits communication without authentication or privacy. • authNoPriv — Permits communication with authentication and without privacy. • authPriv — Only permits communication with authentication and privacy. <p>Note: Selecting SNMPv3 does not disable SNMPv1 and SNMPv2.</p>
Authentication User Name	The user name for authentication on the SNMPv3 trap receiver.
Authentication Password	The authentication password is needed for security levels authNoPriv and authPriv.
Authentication Protocol	The supported authentication protocols are MD5 and SHA (Secure Hash Algorithm).
Privacy/Encryption Protocol	The supported privacy protocols are DES (Data Encryption Standard) and AES (Advanced Encryption Standard).
Privacy/Encryption Passphrase	The passphrase is needed for security level authPriv.

To clear SNMPv3 configuration options:

- Click **Clear SNMPv3 Options**.
- Click **Yes** when prompted to confirm this action.

CONFIGURING EVENT NOTIFICATION PARAMETERS

You can enable SMTP (Simple Mail Transfer Protocol) functionality and configure email notification of library events to one email address from the **Configuration > Network Management > SMTP** screen. The library must have network access to an SMTP server.

Configuration > Network Management > SMTP

SMTP Enabled:

Notification Level: + Warning ▾

SMTP Server:

Security: None ▾

SMTP Port: Default SMTP Port: 25 ▾

To Email Address:

Mailer Name:

Email Subject:

Emailer Address:

Authentication Required:

Username:

Password:

NOTE: The Submit button will perform any changes made on the page and send a test email.

Figure 25 The SMTP screen.

1. Select the **SMTP Enabled** check box to enable SMTP. When selected, the configuration entry fields become accessible.
2. Enter the required information.

Field	Description
Notification Level	<p>The types of events for which the library should send email.</p> <ul style="list-style-type: none"> • Inactive—No events are sent. • Critical—Only critical events are sent. • + Warnings—Only critical and warning events are sent. • + Configuration—Only critical, warning, and configuration events are sent.

Field	Description
	<ul style="list-style-type: none"> • + Information—All events are sent.
SMTP Server	The Hostname (if DNS is configured) or IP address (if DNS is not configured) of the SMTP server.
Security	<p>The security protocol for accessing the SMTP server.</p> <ul style="list-style-type: none"> • None • SSL => SSL/TLS • TLS = STARTTLS
SMTP Port	<p>The default port for the selected protocol is selected. You can choose one of the default ports or configure a custom port.</p> <ul style="list-style-type: none"> • Default SMTP Port: 25 • SMTP Over SSL: 465 • Alternate Port: 587 • Custom - If selected, enter a port number.
To Email Address	The email address to receive the reported events (for example <i>firstname.lastname@example.com</i>). If desired, multiple email addresses can be configured.
Mailer Name	Name to display as the sender of the email.
Email Subject	Subject line for the email message.
Mailer Address	The email address that displays as the sender whenever the library generates an email. This email address should uniquely identify the library to assist in troubleshooting, and be recognized by the SMTP server as a valid domain address.
Authentication Required	When selected, a username and password are required to access the SMTP server.
Username	User account for logging into the SMTP server when authentication is required.
Password	Password associated with the Username when authentication is required.

3. Click **Submit**.

CONFIGURING TAPE DRIVES

You can see and modify drive configuration from the **Configuration > Drives** screen.

The screenshot shows the 'Configuration > Drives > Settings' interface. It features two drive configuration sections. The first section is for 'Drive: 1 (LUN)S/N: 11C48BE0DD', which is an IBM LTO 6 HH FC drive with power on. It shows firmware G9P1 and manufacturer S/N 10WT007466, with a 'Power On' checkbox checked. Below this is the 'Port A Configuration' section with dropdown menus for Speed (Automatic), Port Type (Automatic), Addressing Mode (Soft), and Loop ID / ALPA (Automatic). The second section is for 'Drive: 2 (LUN)S/N: 11C48BE10F', an IBM LTO 6 HH SAS drive with power on, showing firmware H991 and manufacturer S/N 10WT007198, also with a 'Power On' checkbox checked. At the bottom are 'Submit' and 'Undo' buttons.

Figure 26 The Drives Settings screen.

Click the drive number to expand the section. The following information displays for each tape drive:

Field	Description
Drive Number	Tape drives are numbered from the bottom of the library up to the top beginning with "1". The drive currently hosting the SCSI communication for the library is designated with (LUN).
Serial Number	The serial number assigned to the tape drive by the Spectra SL3 library. This serial number is reported to host applications. The serial number cannot be modified. Note: This is not the serial number assigned to the tape drive by the tape drive manufacturer; the serial number assigned by the manufacturer is shown in Manufacturer S/N.
LTO generation	The LTO generation of the drive.
Drive form factor	<ul style="list-style-type: none"> • HH - half height
Drive interface	<ul style="list-style-type: none"> • FC - Fibre Channel • SAS - Serial Attached SCSI

Field	Description
(Modified)	When present, this indicates that a setting has been changed, but not applied. To apply the changes, click Submit . To reset all changed fields to their previously saved values, click Undo .
Pwr	Indicates whether the drive is currently powered on or off.
Firmware	The version of firmware currently installed in the tape drive.
Manufacturer S/N	The serial number assigned to the drive when it was manufactured. Use this serial number when working with your service provider.
Power On	Selected when the drive is powered on. Note: Always power off a tape drive before removing it from the library or moving it to a new location within the library.
Port configuration (FC only)	The drive port configuration. <ul style="list-style-type: none"> • Speed -The currently selected Fibre Port speed. The default is Automatic. • Port Type <ul style="list-style-type: none"> • Automatic (default) • Fabric • Loop - Enables selection of the Addressing Mode. • Addressing Mode - When Port Type is set to Loop, Addressing Mode can be set to Soft or Hard addressing. • ALPA - When Addressing Mode is set to Hard, you can choose an ALPA address from the drop down list.

To modify the configuration of one or more tape drives:

1. Modify any of the configurable values.
2. Click **Submit**.

ENABLING OR DISABLING MAILSLOTS

The **Configuration > Mailslot** screen lists each of the mailslots and shows whether each is enabled or disabled.

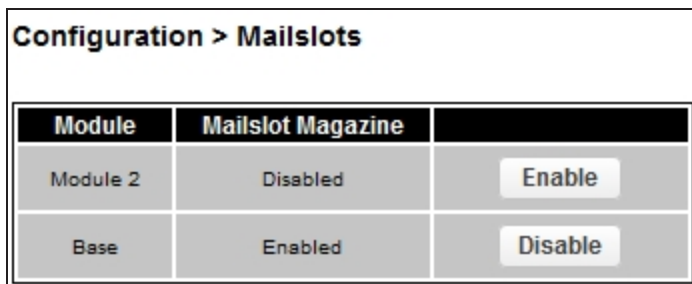

Module	Mailslot Magazine	
Module 2	Disabled	Enable
Base	Enabled	Disable

Figure 27 The Configuration Mailslots screen.

1. To change the mailslot state, click **Enable** or **Disable** next to the appropriate module.
2. Click **Submit** to save your selections.

CONFIGURING LIBRARY PARTITIONS

**IMPORTANT**

Partitions can only be created using the RMI (Remote Management Interface).

Partitions on the Spectra SL3 library have the following restrictions:

- Each partition must have at least one tape drive. One drive in each partition hosts the robotics interface (the library LUN) for the partition.
- The maximum number of partitions allowed is 21.
- Magazine slots are allocated in five-slot groups.
- Mailslots must be enabled for a module before they can be allocated to a partition.

A partition does not need to have a mailslot. If a partition does not have a mailslot, the magazine must be accessed to import or export cartridges. Opening a magazine takes the library offline.

Although the mailslot magazine is shared between partitions, the mailslot elements are assigned individually to partitions. Wizards guide you through the partition configuration process. The wizards are only accessible from the RMI.

- All of the partitions in the library go offline while partitions are configured. Ensure that host operations for all partitions are idle before running a partition wizard.

Partition configuration wizards guide you through the process. The wizards are only accessible from the RMI. Use the Basic Partition Wizard to configure partitions that have similar resources. Use the Expert Partition Wizard to configure partitions that have different resources or to adjust resource assignments for existing partitions.

- Basic Partition Wizard - Any currently configured partitions are deleted. You specify the number of partitions and the wizard assigns drives and storage slots as evenly as possible to the partitions. Any extra drives or slots are assigned to the first partition.
- Expert Partition Wizard - Can be used to edit or remove current partitions or create the first or an additional new partition. New partitions are created individually and you control the library resources assigned.

Using the Basic Partition Wizard

You must create at least one partition before you can use your SL3 library for data backup operations. The following instructions guide you through partition creation using the Basic Wizard, which creates one or more partitions using all tape drives and licensed slots in the library.

**IMPORTANT**

With the Basic Wizard, all previously configured partitions are deleted. Ensure that host operations for all partitions are idle before running the partition wizard.

Note: If you want to configure advanced partition settings, see [Configuring the Library on page 48](#) for instructions on using the partition Expert Wizard. Use the Expert Wizard to create additional partitions without deleting current partitions, to configure partitions that have different resources or to adjust resource assignments for existing partitions.

Use the instructions below to create partitions using the Basic Partition Wizard:

1. From the home screen of the library interface, select **Configuration > Basic Wizard** to start the wizard.
2. On the right-hand pane, select **Basic Wizard**. The Information screen of the Basic Wizard displays.

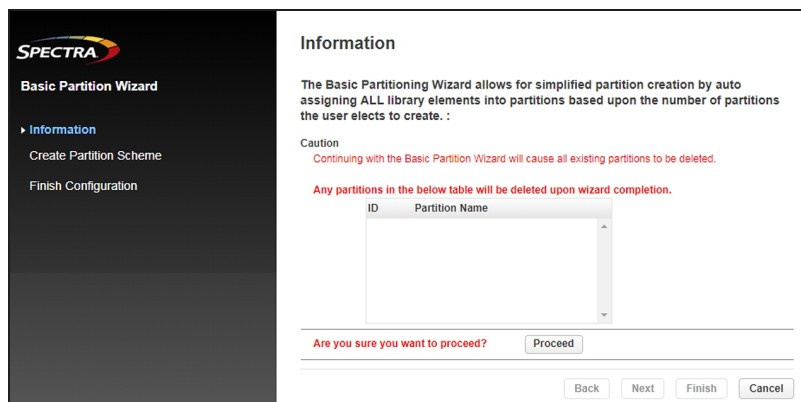

Figure 28 The Information screen.

3. A warning displays that the Basic Wizard deletes any existing partitions. Click **Proceed** and then click **Next**. The Create Partition Scheme screen displays.

Notes:

- If the resources displayed do not match your configuration, you may need to install license keys. See [Configuring the Library on page 48](#).

4. The **Create Partition Scheme** screen displays the number of slots, mailslots, tape drives, and maximum available partitions for the library.
5. Select the number of partitions to create.
6. Use the **Barcode Label Length Reported To Host** drop-down menu to select the number of digits on a tape barcode that are reported to your backup software. This option provides interchange compatibility with libraries with more limited barcode reading capabilities. The maximum barcode character length is 16 and the default is 8. This configuration applies to all partitions.

Note: The industry standard length for LTO barcode labels is eight characters. Barcode labels longer than eight characters might scan incorrectly, particularly if they are not high quality labels.

7. Use the **Barcode Label Alignment Reported To Host** drop-down menu to configure the library to report the barcode digits to the backup software starting from the left or right side of the barcode. The default setting is left. For example, when reporting only six characters of the barcode label 12345678, if alignment is left, the library reports 123456. If alignment is right, the library reports 345678. The default is left.
8. Click **Next**. The Finish Configuration screen displays with details for the partition(s) configured using the wizard.

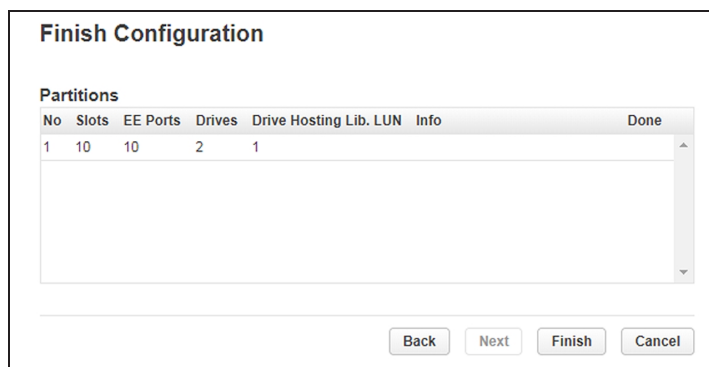

Figure 29 The Finish Configuration screen.

9. Click **Finish** to create the partition(s) and exit the wizard.

Using the Expert Partition Wizard

Select **Configuration > Partitions > Expert Wizard** to start the wizard. The Manage Partitions screen lists the current partitions, if any, and the free resources. Use this wizard to configure one partition at a time.

- Notes:**
- If you want to enable or disable mailslots, click **Cancel** to leave the wizard and update the mailslot configuration (see [Configuring the Library on page 48](#)) before configuring partitions.
 - All of the partitions in the library go offline while partitions are configured. Ensure that host operations for all partitions are idle before running the partition wizard.

Add or Edit a Partition

Use the instructions below to create partitions using the Expert Partition Wizard:

1. Click **Add** to create a new partition or select the partition and click **Edit** to edit an existing partition, and then click **Next**. The General Settings screen displays.

Note: The **Add** button is only active if there are available resources. If there are no available resources, either edit a partition to free up resources for a new partition, or remove a partition.

2. Enter a **Partition Name**.

3. Use the **Barcode Label Length Reported To Host** drop-down menu to select the number of digits on a tape barcode that are reported to your backup software. This option provides interchange compatibility with libraries with more limited barcode reading capabilities. The maximum barcode character length is 16 and the default is 8. This configuration applies to all partitions.

Note: The industry standard length for LTO barcode labels is eight characters. Barcode labels longer than eight characters might scan incorrectly, particularly if they are not high quality labels.

4. Use the **Barcode Label Alignment Reported To Host** drop-down menu to configure the library to report from the left or right end of the barcode label to the host application when reporting fewer than the maximum number of characters.

For example, when reporting only six characters of the barcode label 12345678, if alignment is left, the library reports 123456. If alignment is right, the library reports 345678. The default is left.

5. In the **Assign Storage Slots** screen, use the >> and << buttons to assign slots to the new partition and then click **Next**.
6. In the **Assign Mail Slots** screen, use the >> and << buttons to assign mailslots to the new partition and then click **Next**. Individual mailslot elements cannot be shared between partitions. Importing or exporting cartridges in a partition without an assigned mailslot will require magazine access, which will take the library offline.

7. In the **Assign Drives** screen, use the >> and << buttons to assign drives to the new partition and then click **Next**.
8. If the partition has multiple tape drives, select the drive to host the SCSI communication for the partition.

Note: The lowest numbered drive in the partition is selected as the default.

9. Click **Next**. The Finish Configuration screen displays.

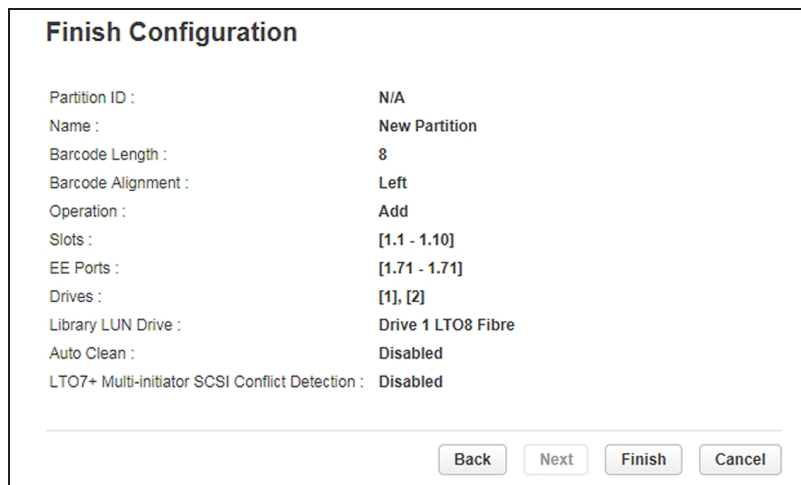

The screenshot shows a window titled "Finish Configuration" with the following details:

Partition ID :	N/A
Name :	New Partition
Barcode Length :	8
Barcode Alignment :	Left
Operation :	Add
Slots :	[1.1 - 1.10]
EE Ports :	[1.71 - 1.71]
Drives :	[1], [2]
Library LUN Drive :	Drive 1 LTO8 Fibre
Auto Clean :	Disabled
LTO7+ Multi-initiator SCSI Conflict Detection :	Disabled

At the bottom right, there are four buttons: Back, Next, Finish, and Cancel.

Figure 30 The Finish Configuration screen.

10. Verify the partition configuration and then click **Finish**.

After the wizard creates or reconfigures the partition, the library comes online automatically.

Remove a Partition

1. On the Manage Partitions screen (see Chapter 3 on page 48), select the partition to remove.
2. Click **Remove**, and then click **Next**.
3. Verify that you want to remove the partition and click **Finish**.

After the wizard removes the partition, the library comes online automatically.

CONFIGURE ENCRYPTION

The **Configuration > Encryption** page provides several options to set encryption mode. To set the Default Encryption Mode for new Partitions select the encryption mode from the drop-down menu.

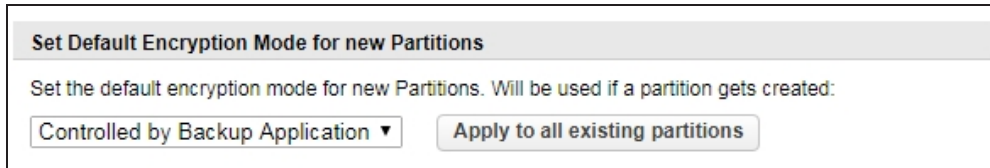

Figure 31 The Set Default Encryption Mode for new Partitions screen.

Click **Apply to all exiting partitions** to set the selected encryption mode for all exiting partitions. Click **Submit** to activate the encryption modes.

KMIP Wizard

The library supports integration with encryption key management servers using the KMIP standard. These key management servers support sharing encryption keys with different libraries, which can be in different physical locations.

With the Key Management Interoperability Protocol (KMIP) Wizard you can configure use of KMIP key management servers with the library. Access to the wizard from the **Configuration > Encryption** menu is only available to the Security user and requires that the KMIP license has been added from the **Configuration > System > License Key Handling** screen.

Before running the wizard, verify that the library configuration is complete, including defining all library partitions, and verify the KMIP server is available on the network and is configured for use with the library.

Using the KMIP Wizard

Use the following instructions to set up KMIP encryption management.

1. Select **Configuration > Encryption > KMIP Wizard**. The Wizard Information screen displays.

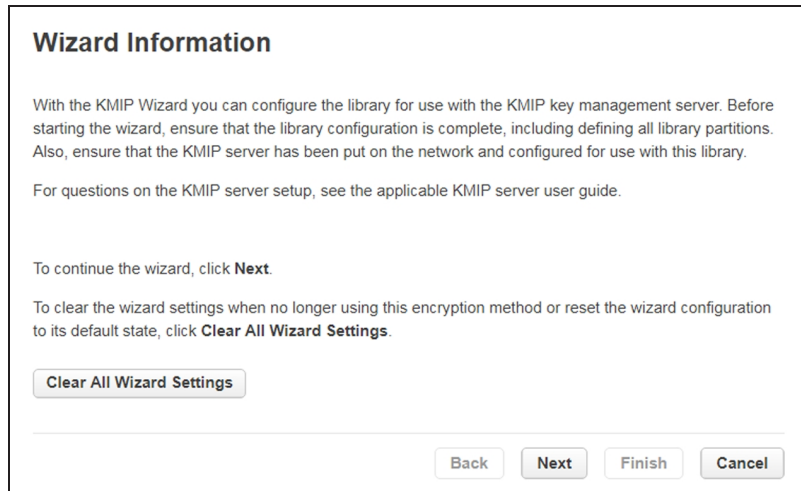

Figure 32 The KMIP Wizard Information screen.

2. To disable KMIP encryption, click **Clear All Wizard Settings**. To set up KMIP encryption, click **Next**. The Certificate Authority Information screen displays.

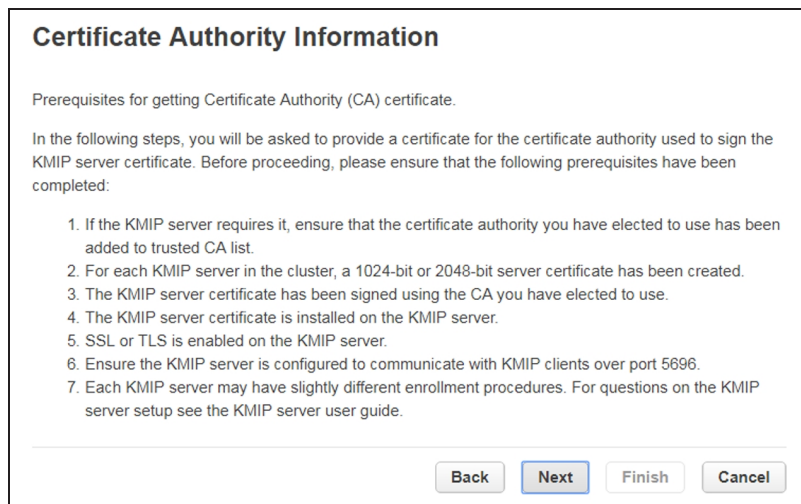
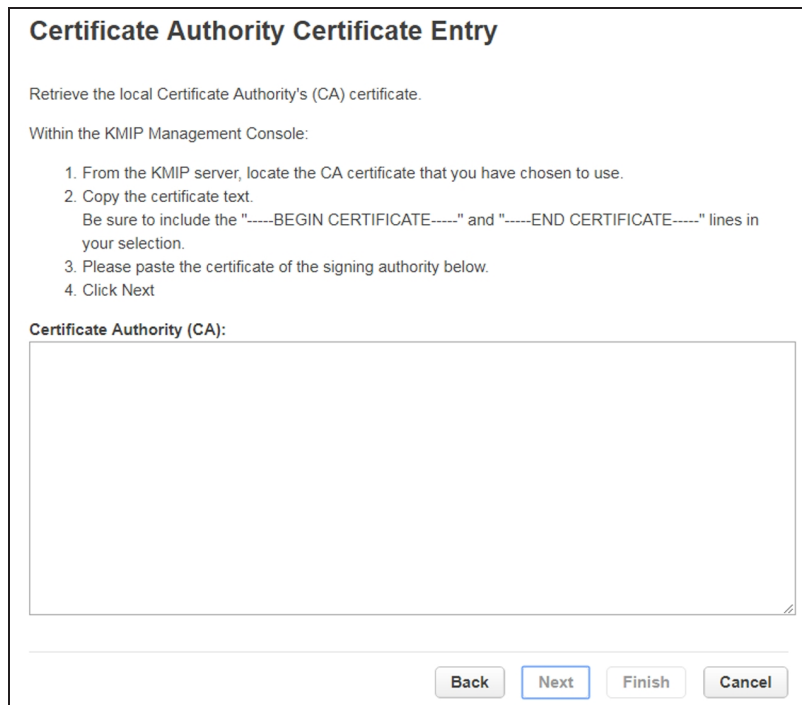

Figure 33 The Certificate Authority Information screen.

3. Ensure that all prerequisites for using the KMIP certificate are met and click **Next**. The Certificate Authority Certificate Entry screen displays.



Certificate Authority Certificate Entry

Retrieve the local Certificate Authority's (CA) certificate.

Within the KMIP Management Console:

1. From the KMIP server, locate the CA certificate that you have chosen to use.
2. Copy the certificate text.
Be sure to include the "-----BEGIN CERTIFICATE-----" and "-----END CERTIFICATE-----" lines in your selection.
3. Please paste the certificate of the signing authority below.
4. Click Next

Certificate Authority (CA):

Figure 34 The Certificate Authority Certificate Entry screen.

4. Follow the on-screen instructions to obtain and copy the certificate from the KMIP server management console. Paste the certificate into the wizard and then click **Next**. The Library Certificate Information screen displays.

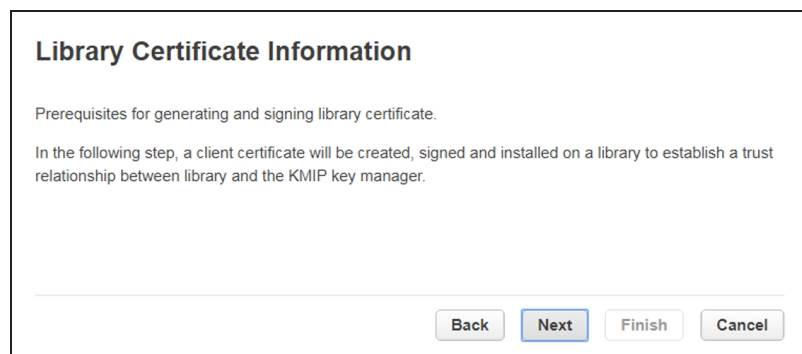

Library Certificate Information

Prerequisites for generating and signing library certificate.

In the following step, a client certificate will be created, signed and installed on a library to establish a trust relationship between library and the KMIP key manager.

Figure 35 The Library Certificate Information screen.

5. The Library Certificate Information screen displays information about the next wizard steps. Click **Next**. The KMIP Client Configuration screen displays.

KMIP Client Configuration

Enter the KMIP server settings.

Enter the username and password that will be used by the library for authentication while connecting to the KMIP server. These should be the same as the username and password that were specified on the KMIP management console for this library.

Client Username:

Client Password:

Confirm Password:

Some KMIP Servers do not use a client user name and client password as part of authentication, and instead use only certificate passing for authentication. Only enable Certificate-only authentication if you are using a KMIP Server that requires it.

Enable KMIP Certificate-only authentication

Figure 36 The KMIP Client Configuration screen.

6. The KMIP Client Configuration screen provides options for two types of server authentication.
 - If your KMIP server uses a client username and password for authentication, enter the username and password that were specified on the KMIP management console for the library. This is recommended if available.
 - If your KMIP server uses only certificate passing for authentication, select **Enable KMIP Certificate-only authentication**. Only select this option if you are using a KMIP server that requires it and you do not have a client username and password.

7. Click **Next**. The Certificate Generation screen displays.



Figure 37 The Certificate Generation screen.

8. The Certificate Generation screen displays the current library certificate, if one exists.
- To use the current certificate, select **Keep Current Certificate** and then click **Next**. The KMIP Server Configuration screen displays. Skip to Step Chapter 3 on page 48.
 - To generate a new certificate, select **Generate New Certificate**. The wizard generates and displays a new library certificate. Click **Select Certificate** and press **CTRL-C** to copy the new certificate text, and then click **Next**. The Sign Library Certificate screen displays.

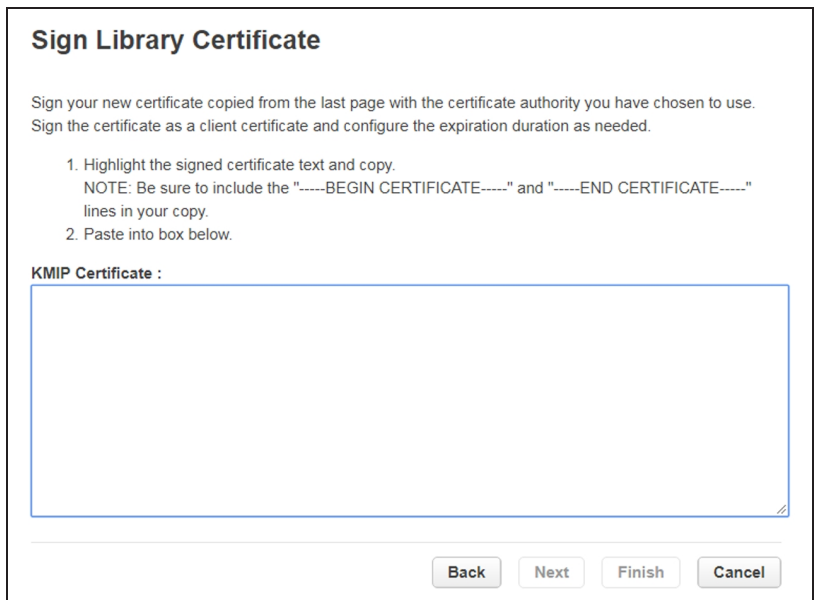

Figure 38 The Sign Library Certificate screen.

- Sign the new library certificate with the certificate authority as a client certificate. Press CTRL-V to paste the new KMIP certificate in the box, and then click **Next**. The KMIP Server Configuration screen displays.

KMIP Server Configuration

Enter the KMIP server IP/hostname information. Up to ten KMIP servers can be configured. The default KMIP port is 5696.

After entering in the KMIP server information, use the Connectivity Check button to validate KMIP server connectivity authentication.

	IP Address/FQ hostname:	Port:		IP Address/FQ hostname:	Port:
NODE1:		5696	NODE6:		5696
NODE2:		5696	NODE7:		5696
NODE3:		5696	NODE8:		5696
NODE4:		5696	NODE9:		5696
NODE5:		5696	NODE10:		5696

Connectivity Check

Figure 39 The KMIP Server Configuration screen.

- In the KMIP Server Configuration screen, enter the IP address or fully-qualified hostname and port number for up to ten KMIP servers. To verify access to the KMIP server(s), click **Connectivity Check**. Click **Next** to continue. The Setup Summary screen displays.

Setup Summary

Please make sure all settings listed here are correct before submitting the configuration by pressing the Finish button.

Client Username: N/A

▼ Tier1

Task	Info	Done
Library Certificate	Finished	✓
KMIP Certificate	Finished	✓
Connectivity Check	Skipped	✓
KMIP Server Settings Saved		
Store Configuration To System		

Figure 40 The Setup Summary screen.

- The Setup Summary screen displays the settings that were configured by the wizard. Verify that the settings are correct and that no errors display in the Done column. If you need to modify any settings or fix any issues, either click **Back** to reach the applicable screen or **Cancel** out of the wizard to fix the issues and return later. When the settings are all correct, click **Finish**.

CONFIGURE USER ACCOUNTS

Configure User Account Settings

Logged in as a Security user or an Administrator user, from the **Configuration > User Accounts > User Accounts Settings** screen you can set the password rules that apply for all users.

Note: When the settings are changed, they are applied to new passwords. Existing passwords remain the same.

Password Rules	
Minimum Number Of Characters:	8
Minimum Number Of Upper Case Alphabetic Characters (A-Z):	1
Minimum Number Of Lower Case Alphabetic Characters (a-z):	1
Minimum Number Of Numeric Characters (0-9):	1
Minimum Number Of Special Characters (!@#\$%^&*()_+={} ~:"'<>?,./):	0
Maximum Number Of Identical Consecutive Characters:	2
Maximum Number Of Failed Logins Before Password Is Locked:	3
Maximum Number Of Days Before Password Must Be Changed:	90
Number Of Password Changes Before An Old Password Can Be Used Again:	3
Submit	

Figure 41 The User Account Settings screen.

Configure Password Rules

Select any password rules that you want to apply and then click **Submit**.

- **Minimum Number Of Characters**—Choose the minimum password length. The factory default value is 8. Possible range for this option is from 8 to 20. The maximum password length is 128.
- **Minimum Number Of Upper Case Alphabetic Characters (A-Z)**—Choose the minimum number of upper case alphabetic characters. The factory default value is 0. Possible range for this option is from 0 to 3.
- **Minimum Number Of Lower Case Alphabetic Characters (a-z)**—Choose the minimum number of lower case alphabetic characters. The factory default value is 0. Possible range for this option is from 0 to 3.
- **Minimum Number Of Numeric Characters (0-9)**—Choose the minimum number of numeric characters. The factory default value is 0. Possible range for this option is from 0 to 3.

- **Minimum Number Of Special Characters (!@#\$%^&*()_+={}|[]\;:'" <>?,./)**—Choose the minimum number of special characters. The factory default value is 0. Possible range for this option is from 0 to 3.
- **Maximum Number Of Identical Consecutive Characters**—Choose the maximum number of identical consecutive characters. The factory default value is unlimited. Possible range for this option is from 1 to 3, or unlimited.
- **Maximum Number Of Failed Logins Before Password Is Locked**—Choose the maximum number of failed logins before the password is locked. The factory default value is unlimited. Possible range for this option is from 1 to 10, or unlimited.

**CAUTION**

When a password is locked, the login cannot continue. Either the user must complete a valid login with an administrator account where the administrator can change a password or request a temporary password.

- **Maximum Number Of Days Before Password Must Be Changed**—Choose the maximum number of days before the password must be changed. The factory default value is unlimited. Possible range for this option is from 1 to 365, or unlimited.
- **Number Of Password Changes Before An Old Password Can Be Used Again**—Choose the number of password changes before the password can be re-used. The factory default value is 0. Possible range for this option is from 1 to 6.

Two-Factor Authentication

The Spectra SL3 library offers two-factor authentication as part of Attack Hardened storage, which enhances the security of your library by using an authenticator application to confirm the identity of a user trying to log in to the library. This prevents unauthorized access to the library even if the user credentials needed to access the system are compromised.

Two-factor authentication works on a per-user basis by generating a token in the form of a QR code for a selected system user. The user scans the QR code using an authenticator application to complete the account creation. After the QR code is scanned, the authenticator generates a six-digit number every 30 seconds and does not require cell or internet access to generate these codes.

After two-factor authentication is enabled, when the user attempts to log in to the SL3 user interface, after entering their username and password, they must enter the six-digit number generated by the authenticator within 30 seconds to complete the login.

Spectra Logic has tested the Google Authenticator phone application, the Microsoft Authenticator phone application, and the *authenticator.cc* plugin to the Google Chrome browser.

Note: If you plan to enable two-factor authentication for a user(s), you must enable SNTP before you can use two-factor authentication. See [Configuring the Library](#) on page 48.

Configure Local User Accounts

From the **Configuration > User Accounts > Local User Accounts** screen you can add local users or set a new password for the user, administrator, security, or service accounts.

- Notes:**
- An Administrator user can add a user or change the password for a user with an administrator or user role and change role permissions.
 - A Security user can add a security user or change the password for a security user and change role permissions.
 - A Service user can add a security user or change the password for a security user.
 - A user with the user role cannot access this screen.

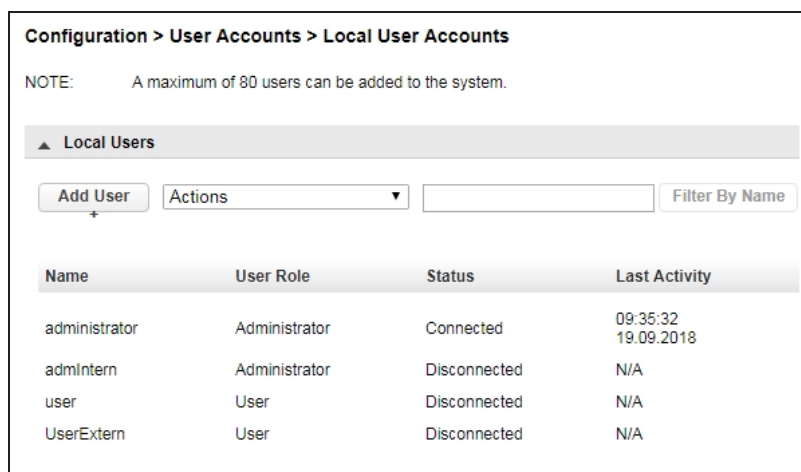
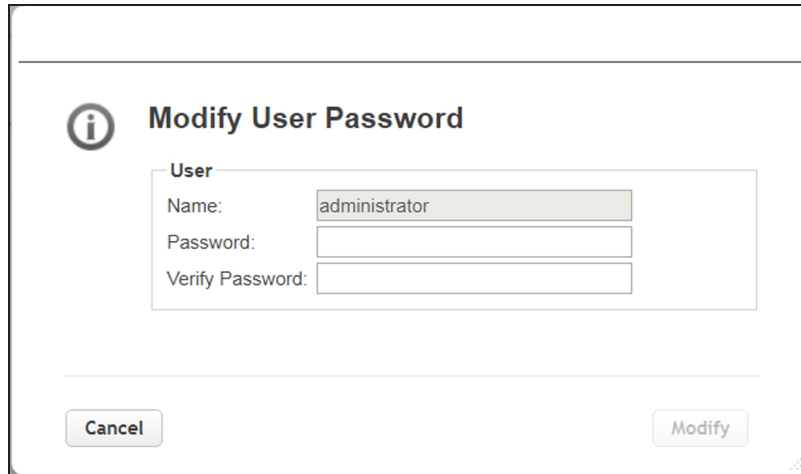

Figure 42 The Local User Accounts screen (Administrator logged in).

Change Passwords

1. Click **Edit** next to the user for which you want to change the password. The Modify User Password dialog box displays.

- Notes:**
- A password is not required for the default user account.
 - The library initially has a null administrator password. A password must be set using the OCP before the Administrator can access the library from the RMI. Once the Administrator password has been set from the OCP, it can be changed by the Administrator user from either the OCP or RMI.
 - The default password for the Security user is **security**. The password must be modified using the OCP before the Security user can access the library from the RMI. Once the Security password has been set from the OCP, it can be changed by the Security user from either the OCP or RMI.



Modify User Password

User

Name: administrator

Password:

Verify Password:

Cancel Modify

Figure 43 The Modify User Password dialog box.

2. Enter and verify the new password, and then click **Modify**. The dialog box closes to display the Local User Account screen.

Add a User

1. From the **Configuration > User Accounts > Local User Accounts** screen (see Chapter 3 on page 48), click **Add User**. The Add User screen displays.

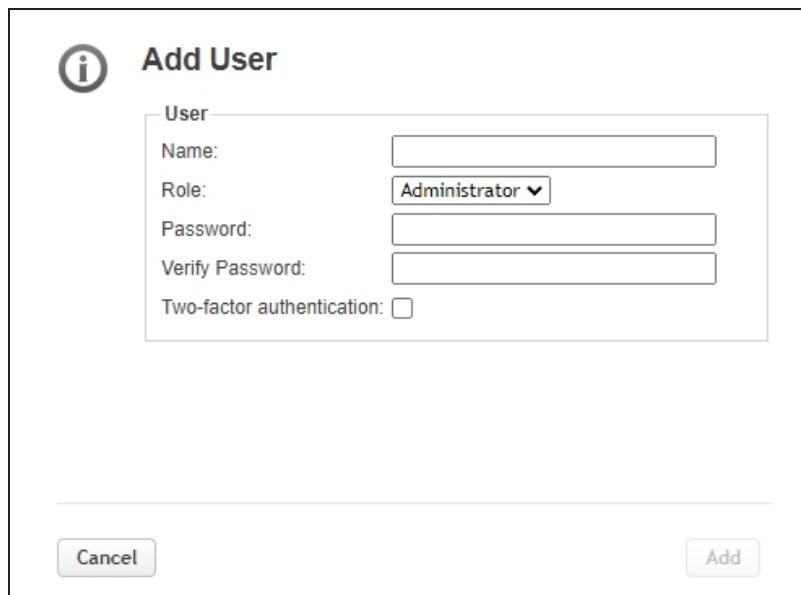

Add User

User

Name:

Role: Administrator

Password:

Verify Password:

Two-factor authentication:

Cancel Add

Figure 44 The Add User screen (Administrator logged in).

2. Enter the **Name** for the user.

3. Select a **Role** for the user:

- **User** — A user account allows access to library status information and does not allow access to configuration, maintenance, or operation features. A password is not required for the default user account, but is required for additional user accounts.
 - **Administrator** — The Administrator account allows access to all configuration, maintenance, and operation features other than encryption.
 - **Security** — A security user has access to all administrator functionality and can also configure security features and change the security user password.
 - **Service** — A service user has access configure security features and change the security user password.
- 4.** Enter and verify the password. The password must meet the configuration options selected in [Configuring the Library on page 48](#).
 - 5.** If desired, select **Two-factor Authentication** to require the user to enter a six digit TOTP (Time-Base One-Time Password) each time they log in to the library. The user must configure an Authentication application the next time they log in.
 - 6.** Click **Add**. The dialog box closes to display the Local User Accounts screen.

Enable Two Factor Authentication for Current User

Use the instructions in this section to edit the current user to enable two-factor authentication.

Note: You must enable SNTP before you can use two-factor authentication. See [Configuring the Library on page 48](#).

- 1.** From the **Configuration > User Accounts > Local User Accounts** screen (see [Chapter 3 on page 48](#)), click **Edit** next to the user you for which you want to enable two-factor authentication. The Modify User screen displays.

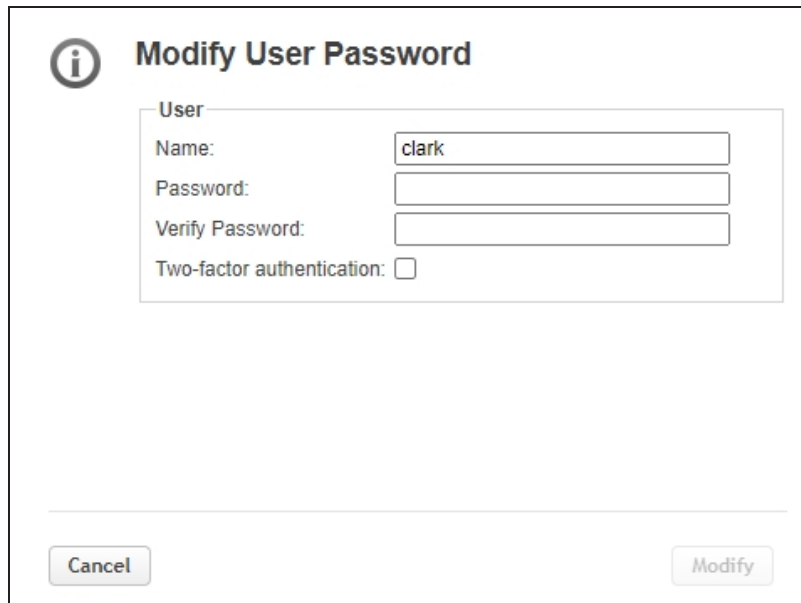

Modify User Password

User

Name:

Password:

Verify Password:

Two-factor authentication:

Figure 45 The Modify User screen.

2. Select **Two-factor Authentication**, then click **Modify**.
 - If you are modifying the currently logged in user, the Setup Authenticator App screen displays. Continue with [Step 3](#).
 - If you are editing a different user, the window closes and the user must configure two-factor authentication the next time they log into the library.
3. Scan the QR code with your phone or similar device, or enter the authentication seed code manually in the **Custom Seed** field. The library appears in your authentication application under the name of your SL3 library.

 **Setup authenticator app**

You can protect your account by one time passwords.
Please setup the one time password protection to continue.

Scan the QR code

Use an authenticator app or browser extension to scan the QR code.
Enter the generated TOTP to verify the setup.



Seed: [Show Seed](#)

Custom Seed (optional):

TOTP:

System Time: 09:06:35 19.09.2024

Timezone: America/Denver

Figure 46 The Modify User screen.

4. Enter the code displayed for the library in your authenticator application in the **TOTP** (Time-Based One-Time Password) field.
5. Click **OK**. The user is now asked for the TOTP code each time they log in to the library.

Configure LDAP

From the **Configuration > User Accounts > LDAP** screen, manage LDAP (Lightweight Directory Access Protocol) servers and users.

Configuration > User Accounts > LDAP

▲ LDAP Servers (Number of configured servers: 0)

Add Server Filter By Primary Server

Action	Primary Server	Port	Secondary Server	Port
--------	----------------	------	------------------	------

▲ LDAP User (Number of configured users: 0)

Add User Filter By Name

Action	Name	Server	User Role
--------	------	--------	-----------

Figure 47 The **Configuration > User Accounts > LDAP** screen.

Add Server

To add an LDAP server, click **Add Server**, the Add Server dialog box displays.

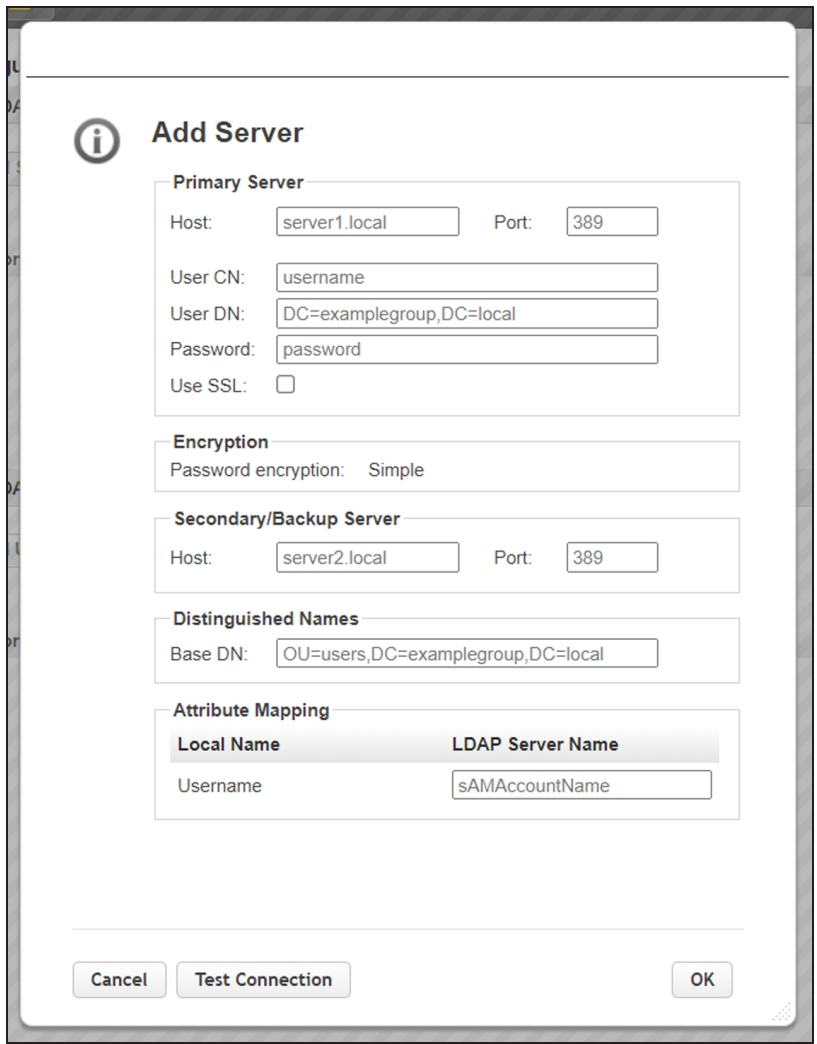

Figure 48 The LDAP Add Server dialog box.

1. Enter the information for the primary server.

Field	Description
Host	The IP address for the LDAP server.
Port	The port on which to communicate with the host. The default is 389.
User CN	The common name for a user with permission to connect to the LDAP server. Many environments use the format “Surname, Name” or the email address for a group of library administrators.
User DN	The distinguished name for the user with the entered User CN. For example: DC=Examplegroup,DC=local.

Field	Description
Password	The password for the user with the entered User CN. This password might be the User CN's Windows password or an environment-specific password.
Use SSL	If required, select Use SSL and then paste the appropriate CA certificate.

2. Enter the Secondary/Backup Server **Host** address and **Port** number.
3. Enter the **Base DN** for Distinguished Names. These are the LDAP parameters needed to identify the LDAP domain. For example: `OU=users,DC=Examplegroup,DC=local`.
4. In the Attribute Mapping pane, enter the **LDAP Server Name** for the specified user account.
5. Click **Test Connection** to verify the server configuration.
6. After verifying the server configuration, click **OK**.

Add User

To add an LDAP user, click **Add User**, the Add User dialog box displays.

The screenshot shows the 'Add User' dialog box. It features an information icon (i) in the top left corner. The main content is organized into three sections:

- Filter:** A section with a 'Username:' label and an empty text input field.
- Query:** A section containing a 'Query LDAP Servers' button. Below the button is the text 'Search Results' and a table with two columns: 'Username' and 'Server'. The table is currently empty.
- Role Assignment:** A section with a 'Role:' label and a dropdown menu showing 'User' with a downward arrow.

At the bottom of the dialog, there are two buttons: 'Cancel' on the left and 'OK' on the right.

Figure 49 The LDAP Add User dialog box.

1. Click **Query LDAP Servers** to see a list of available users.
2. Select a user name and then assign the user a **Role** (User, Administrator, Service, or Security).
3. Click **OK**.

WEB MANAGEMENT

Use the instructions in this section to configure advanced web management features for the RMI.

Security Certificates

From the **Configuration > Web Management** screen select certificate settings and manage security certificates.

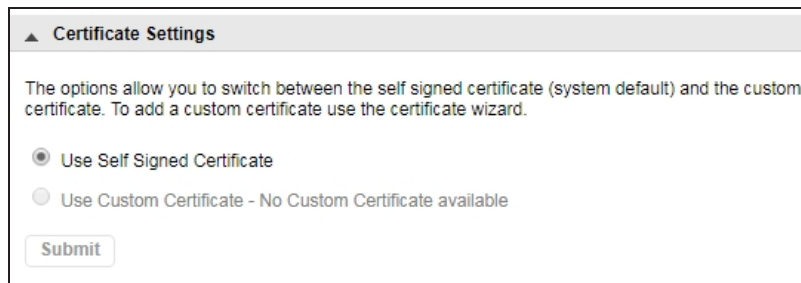

The screenshot shows a window titled "Certificate Settings" with a close button (X) in the top-left corner. Below the title bar, there is a paragraph of text: "The options allow you to switch between the self signed certificate (system default) and the custom certificate. To add a custom certificate use the certificate wizard." Below this text are two radio button options: "Use Self Signed Certificate" (which is selected) and "Use Custom Certificate - No Custom Certificate available". At the bottom of the pane is a "Submit" button.

Figure 50 The Security Certificate panes of the **Configuration > Web Management** screen.

Select Certificate Settings

On the **Configuration > Web Management** screen ([Chapter 3](#)), select **Use Self Signed Certificate** or, if a custom certificate is available, **Use Custom Certificate**, and click **Submit**. If you want to use a custom certificate, but one is not available, continue with [Configuring the Library](#) on page 48.

Add a Security Certificate

Use the following instructions to add a security certificate.

1. On the **Configuration > Web Management** screen, click **Create Custom Certificate** to start the wizard. The Information screen displays.



Figure 51 The Certificate Wizard Information screen.

2. Read the **Information** screen and then click **Next**.
3. Click **Next** to continue. The Certificate Signing Request screen displays.

Figure 52 The Certificate Signing Request screen.

4. Enter the Certificate Request Data and click **Generate CSR**. The certificate displays in the Certificate Sign Request pane.
5. Use a web browser copy command, such as **Ctrl-C** to copy the certificate generated by the wizard. Paste the certificate you copied to your Certificate Authority. Once the certificate is signed, select and copy the entire certificate, and then click **Next**. The Signed Certificate screen displays.



Figure 53 The Signed Certificate screen.

6. Paste the certificate in the Signed Certificate pane and click **Next**. The Finish screen displays.

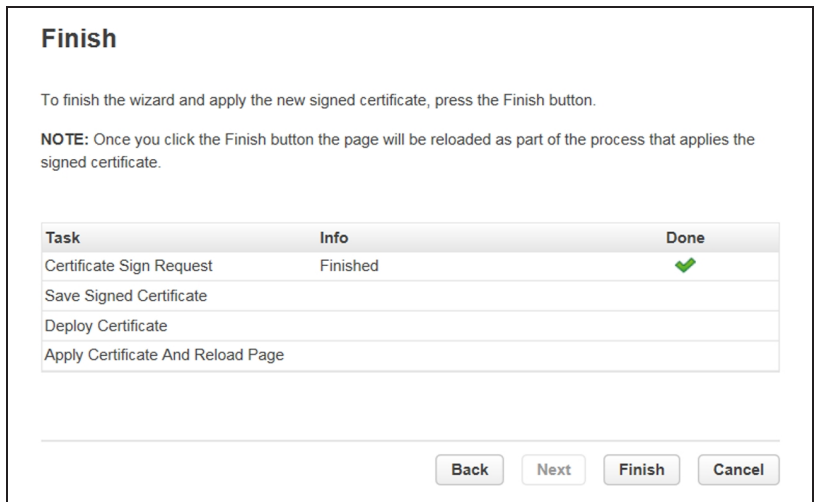

Figure 54 The Finish screen.

7. Click **Finish** to save the certificate and end the wizard.

Backup Custom Certificate

Once you have saved a custom security certificate, click **Backup Custom Certificate** (see Chapter 3 on page 48) and use your browser to save the file.

Restore Custom Certificate

To restore a previously saved custom certificate, click **Browse** and use your browser to locate the certificate file. Then click **Restore Custom Certificate** (see Chapter 3 on page 48).

Session Timeout

On the **Configuration > Web Management** screen, use the Session Timeout pane to configure the session timeout for the RMI/OCP.

The screenshot shows a configuration pane titled "Session Timeout". It contains a label "Select how many minutes a user should stay logged in :" followed by a dropdown menu currently set to "30 min". Below the dropdown is a "Submit" button.

Figure 55 The Session Timeout pane of the **Configuration > Web Management** screen.

Using the drop-down, select how long the user should remain logged in (5 or 30 Minutes) and click **Submit**.

OCP/RMI Session Locking

The library supports only one OCP or RMI session at a time for Administrator, Security, or Service users. By default, when a new user logs in to the RMI or OCP, the existing user session is terminated. Use the OCP/RMI Session Locking pane of the **Configuration > Web Management** screen to change this behavior.

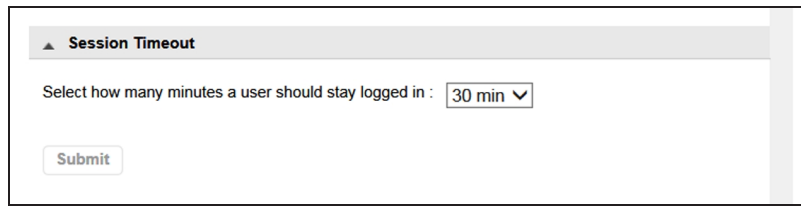
The screenshot shows a configuration pane titled "OCP/RMI Session Locking". It features a checkbox labeled "OCP/RMI Session Locking" which is currently unchecked. Below the checkbox is explanatory text: "This option enables OCP/RMI session locking. The library only supports one OCP or RMI session at a time for the Administrator, Service and Security users. With OCP/RMI session locking enabled, the library will not allow a new Administrator, Service and Security user login until a current session is logged out or times out." A "NOTE" follows: "NOTE: When this setting is enabled, always logout of the RMI or OCP when finished with a session. Otherwise, no new sessions will be allowed until the current session times out." At the bottom is a "Submit" button.

Figure 56 The OCP/RMI Session Locking pane of the **Configuration > Web Management** screen.

When OCP/RMI Session Locking is enabled, a new session does not terminate the current session and the new user will not be able to log in. Select the **OCP/RMI Session Locking** check box and click **Submit** to enable this option.

Restrict RMI Access

To restrict RMI access for the administrator and security users, in the Restricted Remote Management Interface (RMI) Login pane of the **Configuration > Web Management** screen, select the **Restricted Remote Management Interface (RMI) Login** check box and click **Submit**.

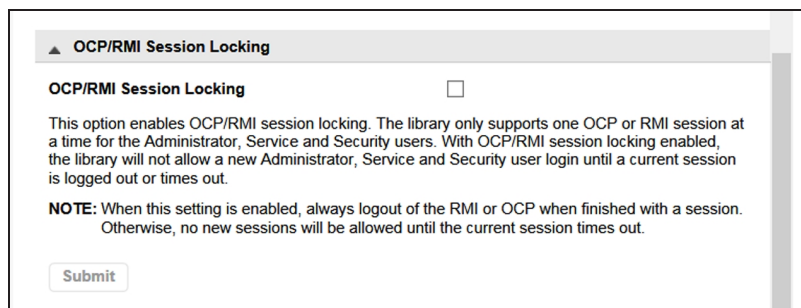
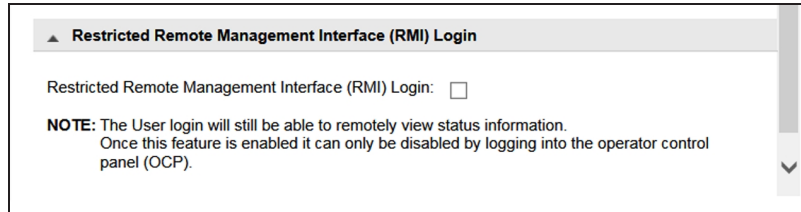

Figure 57 The Restricted Remote Management Interface (RMI) Login pane of the **Configuration > Web Management** screen.

This can be used in high security environments where policies require all configuration changes to occur from the physical library front panel.

Note: Many settings cannot be configured from the OCP.

The user and service users are still able to log in with the RMI. To remove all RMI access, unplug the Ethernet cable from the library controller.

CHAPTER 4 - OPERATING THE LIBRARY

This chapter contains instructions for using your Spectra SL3 tape library. Click **Operations** on the Home screen to access the operations features.

Moving Media	101
Filtering Based on Barcode	101
Moving a Cartridge	102
Opening the Mailslot	103
Opening a Magazine	104
Cleaning a Tape Drive	105
Forcing a Drive to Eject a Cartridge	106
Rescanning the Cartridge Inventory	107

MOVING MEDIA

You can move a tape cartridge located in a source element to an available destination element within the same partition from the **Operation > Move Media** screen.

Operation > Move Media

Barcode Filter On Search

Source Elements				Destination Elements			
Element	Barcode	Module	Part.	Element	Status	Module	Part.
Slot (2.1)	337771L6	2	2	EE Port (2.71)		2	2
Slot (2.2)	337752L6	2	2	EE Port (2.72)		2	2
Slot (2.3)	337772L6	2	2	EE Port (2.73)		2	N/A
Slot (2.16)	339513L6	2	N/A	EE Port (2.74)		2	N/A
Slot (2.17)	337755L6	2	N/A	EE Port (2.75)		2	N/A
Slot (2.18)	337625L6	2	N/A	EE Port (2.76)		2	N/A
Slot (2.21)	337574L6	2	N/A	EE Port (2.77)		2	N/A
Slot (2.22)	339510L6	2	N/A	EE Port (2.78)		2	N/A
Slot (2.23)	337759L6	2	N/A	EE Port (2.79)		2	N/A
Slot (2.24)	339514L6	2	N/A	EE Port (2.80)		2	N/A
				EE Port (3.71)		3	N/A
				EE Port (3.72)		3	N/A
				EE Port (3.73)		3	N/A
				EE Port (3.74)		3	N/A
				EE Port (3.75)		3	N/A
				EE Port (3.76)		3	N/A
				EE Port (3.77)		3	N/A
				EE Port (3.78)		3	N/A

Move Source: to Destination:

Figure 58 The Move Media screen.

- **Source Elements** - Tape drives, enabled mailslots, and storage slots that contain a tape cartridge
- **Destination Elements** - Tape drives, enabled mailslots, and storage slots that do not contain a tape cartridge

Tape drives are in the order of their drive numbers. Tape drives are numbered from the physical bottom of the library starting with Drive (1).

Slots are listed in the order of the slot numbers. Slots are numbered (*m.s*), where *m* is the module number and *s* is the slot within the module. For example, the tape numbered (1, 5) is present in the 5th slot of the first module.

Filtering Based on Barcode

To see a subset of the cartridges in the library based on tape barcodes, enter some or all of the barcode label characters in the search area, and click **Search**. The Source Element list updates to display only the cartridges with labels that include the characters in the search box.

To perform a different search or display all of the available cartridges, click **Barcode Filter Off**.

Moving a Cartridge

1. Select the cartridge from Source Elements.
2. Select the destination element from Destination Elements.
3. Click **Submit**.

OPENING THE MAILSLLOT

From the Home screen, navigate to **Operations > Open Mailslot** to see the status of mailslot port(s) and open any enabled mailslot port in the library. A mailslot port must be enabled before it can be opened. To determine which magazine slots belong to a partition, see [Viewing Library Status](#) on page 108.

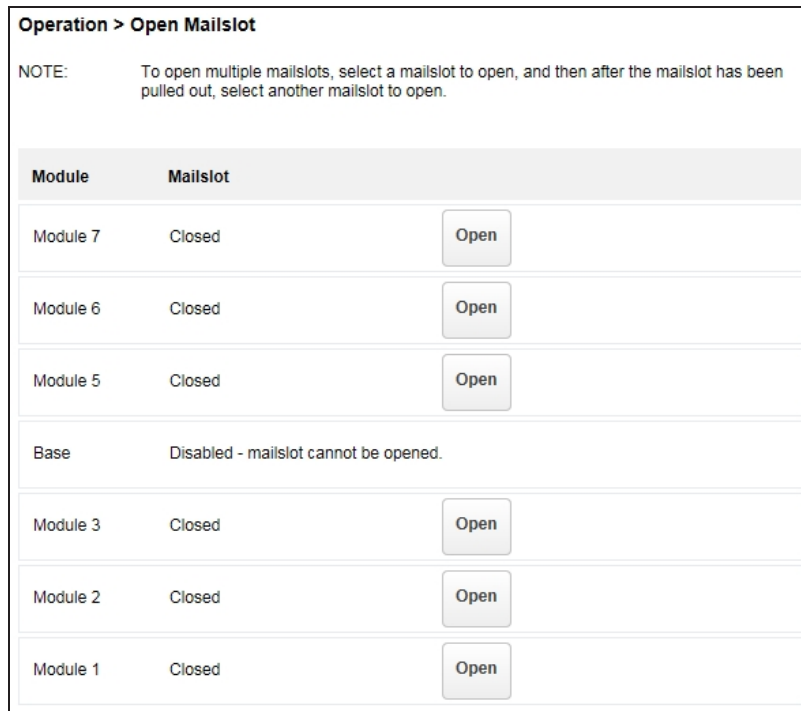

Figure 59 The Open Mailslot Port screen.

To open a mailslot port, click **Open** for the appropriate mailslot. The library releases the lock. Open the door in the appropriate module and then pull the mailslot port out of the library to access the mailslot slot. Close the magazine access door after reinserting the mailslot port.



WARNING

Hazardous moving parts exist inside this product. Do not insert tools or any portion of your body into the interior of the library through the mailslot port door.

Note: If you do not open the door and access the mailslot port within the automatic re-lock duration, the mailslot port re-locks.

OPENING A MAGAZINE

You can unlock any magazine in the library from the **Operation > Open Magazine** screen. To determine which magazine slots belong to a partition, see [Viewing Library Status](#) on page 108.

Operation > Open Magazine				
NOTE: Only one magazine is allowed to be removed at a time.				
Module	Left		Right	
Module 7	Closed	Open	Closed	Open
Module 6	Closed	Open	Closed	Open
Module 5	Closed	Open	Closed	Open
Base	Closed	Open	Closed	Open
Module 3	Closed	Open	Closed	Open

Figure 60 The Open Magazine screen.

To unlock a magazine, click **Open** for the appropriate magazine. The library releases the lock. You can then open the appropriate door and pull the magazine out of the library to access the storage slots.

- Notes:**
- Opening a magazine takes the entire library offline.
 - If you do not open the door and access the magazine within the automatic re-lock duration, the magazine re-locks.

Close the magazine access door after reinserting the magazine.

CLEANING A TAPE DRIVE

You can initiate a drive cleaning operation from the **Operation > Clean Drive** screen.

Source Elements					Destination Elements			
Element	Barcode	Module	Part	Use Count	Element	Status	Module	Part
Slot (2.78)	CLN003L2	2	1	N/A	Drive (1)	1	1	1
					Drive (2)	1	1	1
					Drive (3)	1	1	1

Move Source: to Destination:

Figure 61 The Clean Drive screen.

1. Select a cleaning cartridge from the Source Elements list. The library uses the barcode label to identify cleaning cartridges.
If no cleaning cartridges are available, load one into an mailslot port or magazine slot.
2. Select the tape drive to be cleaned from the Destination Elements list.
Tape drives currently containing a cartridge are not listed. To clean a tape drive not listed, move the cartridge out of the drive.
3. Click **Submit**.

FORCING A DRIVE TO EJECT A CARTRIDGE

The force drive media eject operation attempts to force the tape drive to eject the cartridge and place it into an open slot. Only the Administrator user can force eject a tape cartridge.

Before performing this operation, it is recommended that you attempt to eject the tape using your backup software or a library move media operation (see [Operating the Library on page 100](#)). While a cartridge is being force ejected, a window indicating the process is ongoing displays. No operations are available until the force eject completes.

Note: If the drive has difficulty ejecting the cartridge, the media is possibly bad or damaged. Contact Spectra Logic Technical Support for assistance. See [Contacting Spectra Logic on page 8](#).

Operation > Force Drive Media Eject

Barcode Filter On Search

Source Elements				Destination Elements			
Element	Barcode	Module	Part	Element	Status	Module	Part
Drive (2)	TC063ML5	1	1	Mailslot (1.71)		1	1
				Mailslot (1.72)		1	1
				Mailslot (1.73)		1	1
				Mailslot (1.74)		1	1
				Mailslot (1.75)		1	1
				Mailslot (1.76)		1	1
				Mailslot (1.77)		1	1
				Mailslot (1.78)		1	1
				Mailslot (1.80)		1	1
				Drive (1)	Gen. 5	1	1
				Drive (3)	Gen. 6	1	1
				Slot (1.1)		1	1
				Slot (1.2)		1	1
				Slot (1.3)		1	1
				Slot (1.4)		1	1
				Slot (1.5)		1	1
				Slot (1.6)		1	1

Move Source: to Destination:

Figure 62 The Force Drive Media Eject screen.

1. Navigate to the **Operation > Force Drive Media Eject** screen.
2. Select the drive for which you want to force a tape ejection in the **Source Elements** list.
3. Select the destination in the **Destination Elements** list.
4. Click **Submit**.

RESCANNING THE CARTRIDGE INVENTORY

To rescan the cartridges in the library, navigate to the **Operation > Rescan** screen and click **Rescan**. The library changes to Scanning status and is unavailable to perform other operations until the scan completes.

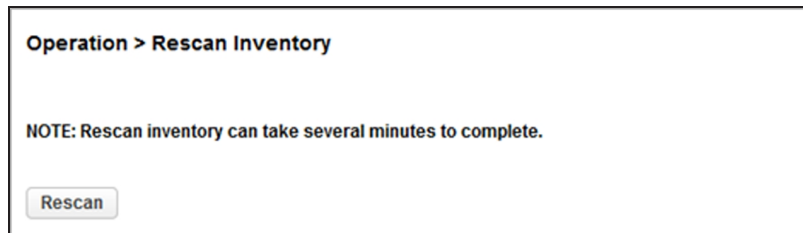

Figure 63 The Rescan Inventory screen.

CHAPTER 5 - VIEWING LIBRARY STATUS

This chapter contains instructions for viewing library status. To access the status area, from the Home screen, click **Status**.

Viewing Library and Module Status	109
Using Inventory Lists	112
Filtering by Barcode Label	114
Listing Just Drives or Cartridges	114
Viewing Elements by Group	114
Using the Cartridge Inventory Graphical View	115
Using Partition Map Graphical View	117
Using Partition Map Configuration Status	119
Viewing Drive Status	121
Viewing Network Status	124
Viewing Encryption Status	126

VIEWING LIBRARY AND MODULE STATUS

Summary information and status is displayed in the top banner and left side bar of the interface. For additional library module configuration and status information navigate to the **Status > Library Status** screen.

Status > Library Status

▲ Library Information

Vendor:	BDT	Product ID:	MULTISTAK
Serial Number:	DE56403901		
Base Firmware Revision:	1.0.0-0003	Expansion Firmware Revision:	MK64: 0.44, GD32F427: 0.04, GD32F470: 0.04
Robotic Hardware Revision:	6	Robotic Firmware Revision:	0.25
Barcode Reader Hardware Revision:	SE-625	Barcode Reader Firmware Revision:	PAAAMC00-002-N09D0
Library Type:	40	Library Config/Spooling:	48U/48U

▲ Library Status

Library Status:	Idle	Total Power On Time:	13d 0h 38m
Cartridge in Transport:	None	Odometer:	79
Robotic Location:	Module 1 (Base)	Shipping Lock:	Unlocked

▲ Module 2

Expansion Controller Revision: E000	Power Supply Status: OK
Lower Power Supply: Present	Upper Power Supply: Not Present
Drive Power Board: OK	
Left Magazine Status: Closed	Right Magazine Status: Closed
Mailslot Status: Closed	Firmware Revision: 0.44

▼ Module 1 (Base)

Figure 64 The Library Status screen.

Field	Description
Library Information	
Vendor	The library vendor.
Serial Number	Library serial number.
Robotic Hardware Revision	Hardware revision of the robotic hardware.

Field	Description
Barcode Reader Hardware Revision	Hardware revision of the barcode reader.
WWide Node Name	A worldwide unique identifier that the library reports over SCSI and can be used by operating systems or software applications to identify and track the library.
Product ID	The product ID.
Library Information (continued)	
Firmware Revision	Version of the currently installed library firmware.
Robotic Firmware Revision	Version of the currently installed robotic assembly firmware. The robotic assembly firmware is bundled and installed with the library firmware.
Barcode Reader Firmware Revision	Version of the currently installed barcode reader firmware. The barcode reader firmware is bundled and installed with the library firmware.
Library Status	
Library Status	<ul style="list-style-type: none"> • Idle - The library robotic assembly is ready to perform an action. • Moving - The library robotic assembly is moving a cartridge. • Scanning - The library robotic assembly is performing an inventory of cartridges. • Offline - The library robotic assembly has been taken offline by the library.
Cartridge in Transport	When applicable, displays the barcode label of the cartridge currently in the robotic assembly.
Total Power On Time	Total time that the controller module has been powered on since it was manufactured using the format <i>dd-hh-mm</i> .
Odometer	Robotic assembly move count.
Robotic Location	Displays the module where the robotic assembly is currently located.
Shipping Lock	Indicates whether the robotic assembly is unlocked or locked for shipment. For normal library operations the lock should always display as Unlocked .
Module Status	

Field	Description
Base Controller Revision or Module Controller Revision	Hardware revision of the controller board currently installed in the module.
Left Drive Power Board Status	Status of the drive power board for the top three half-height drive slots in the module.
Right Drive Power Board Status	Status of the drive power board for the lower three half-height drive slots in the module.
Power Supply Status	Displays the status of power supplies.
Lower/Upper Power Supply Fan	Displays the status of power supply fans.
Chassis Fan	Displays the status of the chassis fan.

USING INVENTORY LISTS

The inventory list displays elements, such as slots and tape drives, as well as information about any cartridges currently located in an element.

- To view the elements organized by module, use **Status > Cartridge Inventory > List View**.
- To see the elements organized by logical library or partition, use **Status > Partition Map > List View**.

Status > Cartridge Inventory > List View

Drives Cartridges Group Off

Filter On

Module	Slot #	Barcode	Full	Gen.	Partition
▲ 1					
	1.1				1
	1.2				1
	1.3				1
	1.4				1
	1.5				1
	1.6				1
	1.7				1
	1.8				1
	1.9				1
	1.10				1
	1.11				1
	1.12				1
	1.13				1
	1.14				1
	1.15				1
	1.16				1
	1.17				1
	1.18	000022L5	X	5	1
	1.19				1
	1.20				1
	1.21				1
	1.22				1
	1.23				1
	1.24				1

Figure 65 The Cartridge Inventory List View screen.

The Inventory List screen displays the following information:

Field	Description
Module	The module number. Click the arrow to the left of the module number to expand or collapse the inventory display for that module.
Slot #	The slot number in the form <i><module>.<slot></i> , where <i>module</i> is the module number and <i>slot</i> is the slot number in that module. See Product Overview on page 21 .
Label	The barcode label of the tape cartridge present in the element.
Full	An X displays if a cartridge is present in the element.
Gen	The LTO generation of the cartridge.
Partition	The partition number to which the element is assigned. To determine the partition name associated with the partition number, see Viewing Library Status on page 108 .

Clicking a full slot displays the following information about the media in the slot:

Field	Description
Media Loads	The number of media loads.
Encryption	Indicates whether data on this media is encrypted or not encrypted.
Media Type	Indicates whether the cartridge is a data or cleaning cartridge.

Filtering by Barcode Label

Use the following instructions to see a subset of the cartridges in the library based on tape barcodes.

1. Click **Filter On**. The search box displays.
2. Enter characters into the search box and click **Search**.

- Notes:**
- The characters can be anywhere in the barcode label.
 - The search characters are not case sensitive.
 - There are no wildcards.

To disable filtering, click **Filter Off**.

Listing Just Drives or Cartridges

- To limit the list to tape drives, click **Drives**. The button changes to read **Slots**. Click **Slots** to return to viewing all elements.
- To limit the list to tape cartridges, click **Cartridges**. The button changes to read **Elements**. Click **Elements** to return to viewing all elements.

Viewing Elements by Group

When the list is grouped, you can expand or contract the list for each group by clicking the triangle next to the number in the first column (Partition or Module). Grouping is enabled by default.

To disable grouping, click **Group Off**.

To enable grouping, click **Group On**.

USING THE CARTRIDGE INVENTORY GRAPHICAL VIEW

The cartridge inventory graphical view displays library elements, such as slots and tape drives, with information about the cartridge stored in the element.

- To see the elements organized by module, from **Status**, navigate to **Cartridge Inventory > Graphical View**.
- To see the elements organized by logical library or partition, see [Viewing Library Status](#) on page 108.

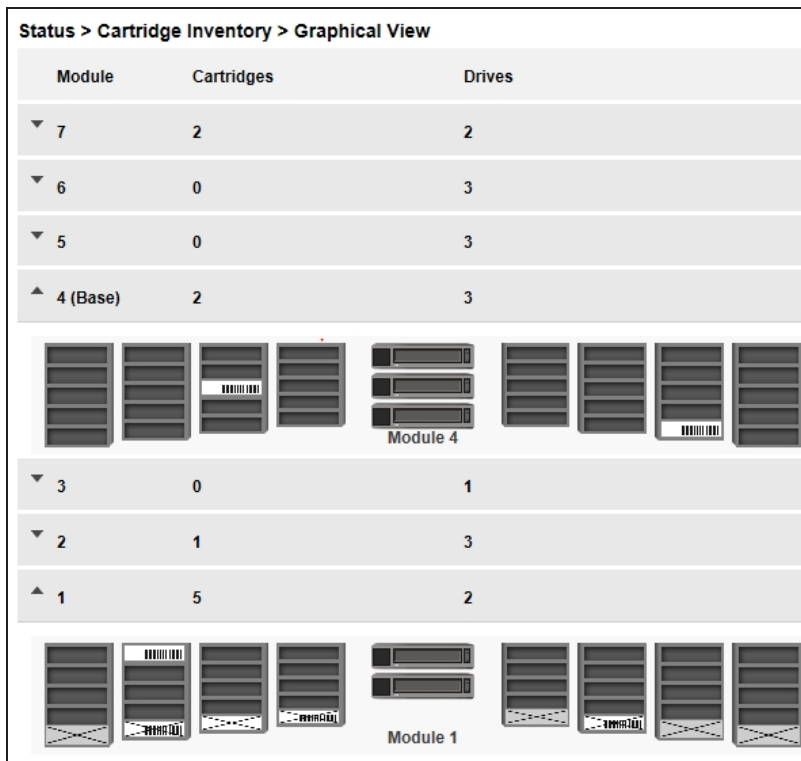

Figure 66 The Cartridge Inventory Graphical View screen.

Moving the mouse over a drive or cartridge to display additional information in a pop-up window.

Field	Description
Drive Information	
Drive	LTO generation of drive and format (Half Height).
Drive #	The drive number. Tape drives are numbered from the bottom of the library up to the top beginning with "1".

Field	Description
Serial #	The serial number assigned to the tape drive by the library.
Cartridge Information	
Barcode	Barcode data on label.
Generation	LTO generation of the cartridge.
Slot #	The slot number in the form <module>.<slot>, where <i>module</i> is the module number and <i>slot</i> is the slot number.
Partition	The partition number to which the cartridge is assigned. To determine the partition name associated with the partition number, see Viewing Library Status on page 108 .
Media Loads	The number of media loads.
Encryption	Indicates whether data on this media is encrypted or not encrypted.
Media Type	Indicates whether the cartridge is a data or cleaning cartridge.

Warning states and error states for drives and cartridges are indicated with icons.

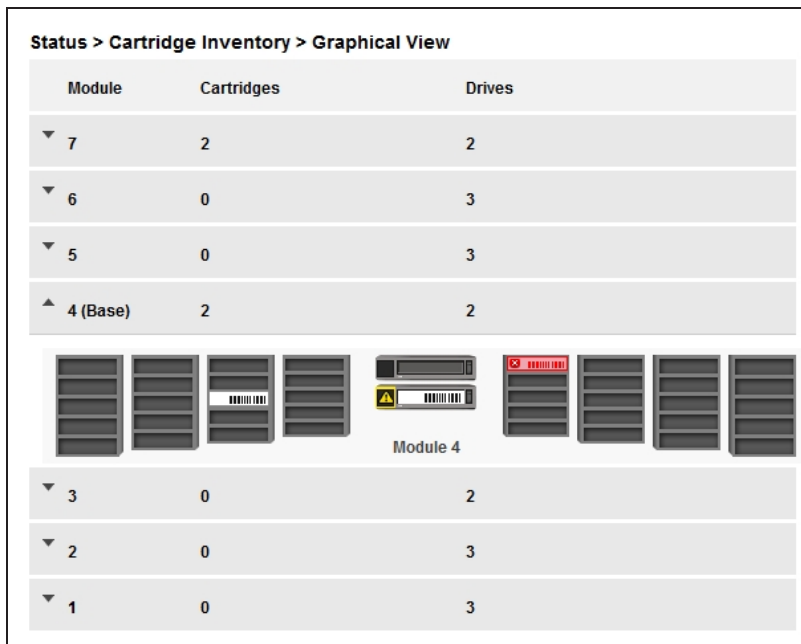

Figure 67 The Cartridge Inventory Graphical View warnings.

USING PARTITION MAP GRAPHICAL VIEW

To see the elements organized by logical library or partition, navigate to **Status > Partition Map > Graphical View**.

For each module, the graphical view of the partition map, from left to right, displays the left magazine banks from front to back, the drives in the module, and the right magazine banks from back to front. Storage slots display in groups of five. If the mailslot port in the module is enabled, the right most bank displays single slots with slot numbers preceded by the letter "M". If an element is configured in a partition, the partition number displays on the element. To determine the partition name associated with the partition number, move the mouse over the partition number.

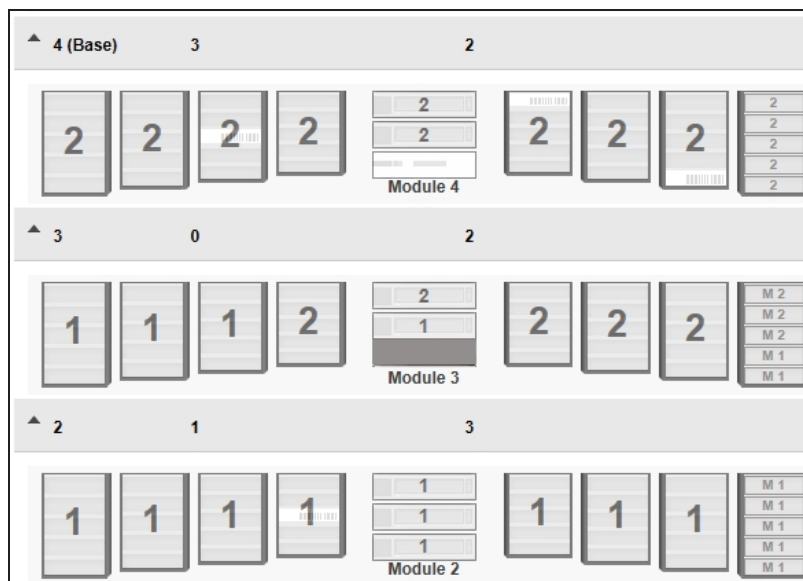

Figure 68 The Partition Map Graphical View screen.

Moving the mouse over a partition or drive displays additional information in a pop-up window:

Field	Description
Partition Information	
Name	Partition name.
Barcode	Barcode reporting settings. See Step Chapter 3 and Step Chapter 3 on page 48 for more information.
Media Removal	Indicates whether media removal is allowed or prevented by the host.

Field	Description
Key Manager Type	The type of encryption used by the partition.
Partition S/N	Serial number of the partition as seen by the host software.
Drive Count	Number of drives configured in this partition.
Slot Count	Number of slots configured in this partition.
Media Count	Number of cartridges in this partition.
Mailslot Count	Number of mailslots configured in this partition.
Drive Information	
Drive #	The drive number. Tape drives are numbered from the bottom of the library up to the top beginning with "1".
Drive	LTO generation of the drive and format (Half Height).
Serial #	The serial number assigned to the tape drive by the library.
Partition	The partition number to which the drive is assigned.
If a cartridge is loaded in the drive	
Partition	The partition number to which this cartridge is configured.
Barcode	Barcode data on label.
Generation	LTO generation of the cartridge.

USING PARTITION MAP CONFIGURATION STATUS

To see the configuration of a partition, its elements and their status, from **Status**, navigate to **Partition Map > Configuration Status**.

Status > Partition Map > Configuration Status

▼ Partition Number: 1 Partition Name: Partition_1

▼ Partition Number: 2 Partition Name: Partition_2

▼ Partition Number: 3 Partition Name: Partition_3

▲ Partition Number: 4 Partition Name: Partition_4

Partition Number: 4
 Partition Name: Partition_4
 Partition S/N: DE0000000_LL04
 Number of Drives: ▼ 3
 Number of Slots: 40
 Number of Mailslots: 5
 Barcode Label Length Rep. to Host: 8
 Barcode Label Alignment Rep. to Host: Left
 Auto Clean: Disabled
 Key Manager Type: Controlled by Backup Application
 Active Control Path Drive: Drive 11 (LTO7 Fibre)
 LTO7 Multi-initiator SCSI Conflict Detection: Disabled

▼ Partition Number: 5 Partition Name: Partition_5

▼ Partition Number: 6 Partition Name: Partition_6

Refresh Expand All

Figure 69 The Partition Map Configuration Status screen.

The Configuration Status screen displays the following information:

Field	Description
Partition Number	The partition number.
Partition Name	The partition name.
Partition S/N	The partition serial number.
Number of Drives	Number of drives configured in this partition.
Number of Slots	Number of slots configured in this partition.

Field	Description
Number of Mailslots	Number of mailslots configured in this partition.
Barcode Label Length Rep. to Host	Barcode length and direction reported to the host. See Step Chapter 3 and Step Chapter 3 on page 48 for more information.
Barcode Label Alignment Rep. to Host	Barcode alignment reported to the host.
Auto Clean	Indicates whether automatic cleaning of drives is enabled or disabled.
Key Manager Type	The type of encryption (host or KMIP) used by the partition. See Configuring the Library on page 48 for more information.
Active Control Path Drive	A drive configured in the partition that provides the control path to the library robotics.
LTO7+ Multi-initiator SCSI Conflict Detection	Whether the library generates a warning event if it detects more than a single host WWNN accessing a drive. See Step Chapter 3 on page 48 for more information.

VIEWING DRIVE STATUS

In the **Status > Drive Status** screen you can see the configuration and status of each drive installed in the library.

Status > Drive Status

#	S/N	Drive Type	Status	Power
1	11C48BE0DD	IBM LTO 6 HH FC	Empty	On
<p>Vendor: IBM Personality: 00 14</p> <p>Firmware: G9P1 Manufacturer S/N: 10WT007466</p> <p>Powered: On WWNN: 5000E111C48BE0DD</p> <p>Temperature: 36 °C Partition: 2 (Library LUN)</p> <p>Encryption: Disabled Cartridge: N/A</p> <p>IP Address: N/A Media Removal: Allowed</p> <p>Module Loc: 1 Data Compression: Enabled</p> <p>Cooling Fan Status: Active Product ID: ULTRIUM-HH6</p>				
Port A Status (WWPN: 5000E111C48BE0DE)				
Speed: 4 Gb/s Port Type: Loop (L)				
Interface: Login complete Loop ID / ALPA: 0x6F / 0x26				
2	11C48BE10F	IBM LTO 6 HH SAS	Empty	On

Refresh Expand All

Figure 70 The Drive Status screen.

In the Drive Status screen you can see:

Field	Description
#	The drive number. Drives are numbered logically from the bottom of the library up to the top beginning with "1".
S/N	The serial number assigned to the tape drive by the library. This serial number is reported to host applications. The serial number cannot be modified. Note: This is not the serial number assigned to the drive by the manufacturer; the serial number assigned by the manufacturer is shown in Manufacturer S/N.
Drive Type	The drive type in the form <i>Vendor LTO gen ff int</i> where. <ul style="list-style-type: none"> <i>Vendor</i> is the manufacturer <i>gen</i> is the generation <i>ff</i> is the form factor (HH: half-height) <i>int</i> is the interface (FC: Fibre Channel or SAS: Serial Attached SCSI)

Field	Description
Drive Health Icon	<ul style="list-style-type: none"> • OK - The green check mark icon indicates the drive is fully operational. • Warning - The yellow exclamation point icon indicates that user attention is necessary, but the drive can continue most operations. • Error - The red X icon indicates that the drive experienced an error that prevents it from continuing normal operations, and user intervention is required. <p>Click the Library Health icon in the top banner for more information about current warnings and errors.</p>
Drive Activity Status	<p>The activity status of the drive.</p> <ul style="list-style-type: none"> • Write—The drive is writing data. • Read—The drive is reading data. • Idle—A cartridge is present in the drive, but the drive is not performing any operations. • Empty—The drive is empty. • Encrypt—The drive is writing encrypted data.
Power Status	Indicates whether the drive is currently powered on or off.
Vendor	The manufacturer of the drive.
Firmware	The currently installed drive firmware version.
Powered	Indicates whether the drive is currently powered on or off.
Temperature	The temperature measured by the tape drive in degrees Celsius.
Encryption	Whether encryption is enabled or disabled.
IP Address	The IP address for the drive. If the drive is does not have an Ethernet connection, a status of “N/A” displays.
Module Loc	The module in which the tape drive is located.
Cooling Fan Status	Whether the tape drive cooling fan is currently active.
Personality	The SCSI Standard Inquiry Data Page which identify the drive vendor.
Manufacturer S/N	The serial number assigned to the drive when it was manufactured. Use this serial number when working with your service provider.
WWNN	The world wide node name assigned to the drive.

Field	Description
Partition	The partition number to which the drive is assigned. If the drive provides the active control path for the partition, "(Library LUN)" displays also.
Cartridge	The barcode of the cartridge in the drive, if applicable.
Media Removal	Indicates whether media removal is allowed or prevented by the host.
Data Compression	Whether data compression is enabled or disabled.
Product ID	ULTRIUM- <i>ff-gen</i> . where <i>ff</i> is the form factor (HH : half-height and <i>gen</i> is the generation).
Port Status - Fibre Channel Drive	<ul style="list-style-type: none"> • The drive port configuration. • WWPN-The world wide port name for the port. • Speed -The currently selected Fibre Port speed. The default is Automatic. • Port Type <ul style="list-style-type: none"> • Automatic • Fabric • Loop- Enables selection of the Addressing Mode. • Interface • Loop ID/ALPA - When Addressing Mode is set to Hard, the ALPA address displays.
Port Status - SAS Drive	<ul style="list-style-type: none"> • The drive port configuration. • WWPN-The world wide port name for the port. • Interface - The connected interface type • Speed -The currently configured SAS port speed.

VIEWING NETWORK STATUS

To see the network status, navigate to **Status > Network Status**.

Status > Network Status

Host Name: [REDACTED]
 Domain Name: [REDACTED]
 Protocol: **IPv4 & IPv6**

▲ **General Network Settings**

MAC Address: [REDACTED] Link Status: **Enabled**
 Link Speed: **1000 Mbit/s** Duplex: **Enabled**

▲ **IPv4**

DHCP: **Enabled**
 Address: [REDACTED] Netmask: **255.255.248.0**
 Gateway: [REDACTED]
 DNS 1: [REDACTED] DNS 2:

▲ **IPv6**

Method: **Stateless**
 Address: [REDACTED]
 Prefix Length: **64**
 Gateway: [REDACTED]
 DNS 1:
 DNS 2:

Figure 71 The Network Status screen.

In the Network Status screen you can see:

Field	Description
Host Name	Library hostname.
Domain Name	The domain name for your network where the library resides.
Protocol	Whether the library network uses IPv4, IPv6, or both addressing methods.
MAC Address	A unique identifier for the library controller network port.
Link Status	Enabled or disabled.
Link Speed	Speed of the Ethernet connection to the library.

Field	Description
Duplex	Enabled or disabled.
IPv4 Settings	
DHCP	When Enabled, the library requests an IP address from a DHCP server each time the library is powered on.
Address	The IP address in use by the library. If DHCP is enabled, this address was obtained from the DHCP server. If DHCP is disabled, the address was manually configured.
Netmask	The network mask of the library controller used when DHCP is disabled.
Gateway	The gateway used when DHCP is disabled.
DNS 1	The first domain name server to access.
DNS 2	The second domain name server to access.
IPv6 Settings	
Stateless Addressing	When enabled, the library generates an address for itself based on the routing information obtained from a router advertisement and the MAC address. The library can manage up to five global addresses at the same time, which can be assigned from different routers.
Static Addressing	When enabled, the library uses a statically-configured address.

VIEWING ENCRYPTION STATUS

Navigate to the **Status > Security** screen to see the status of any key management servers configured for use with the library, as well as the encryption status of the tape drives and partitions.

Status > Security

▲ Security Encryption Status

KMIP: Disabled, Licensed

▲ Partition Encryption Status

▲ Partitions

Partition Number:	Partition Name and S/N:	Encryption Configuration:
1	LTO9Combo, DE56403901_LL02	Controlled by Backup Application

▲ Drive Encryption Status

Drive	Encryption	Partition No.
Drive 1 Offline	Controlled by Backup Application	N/A
Drive 2 Offline	Controlled by Backup Application	N/A
Drive 3	Controlled by Backup Application	1
Drive 4	Controlled by Backup Application	1

Figure 72 The **Status > Security** screen.

The Security Encryption Status pane shows what types of encryption are available in the library, and whether each type is enabled or disabled.

The Partition Encryption Status pane shows what type of encryption is used by each partition and configured Monikers or KMIP servers as applicable. Click **Connectivity Check** (not shown) to initiate a KMIP server connectivity check.

CHAPTER 6 - MAINTAINING THE LIBRARY

This chapter contains instructions for maintaining the library. From the Home screen click **Maintenance** to access the library maintenance features.

Library Tests	128
System Test	128
Slot to Slot Test	129
Element to Element Test	130
Position Test	132
Wellness Test	133
Robotics Test	134
OCP Test and Calibration	134
Logs and Traces	135
Viewing Log Files	135
Downloading Log and Trace Files	136
Configuring Remote Logging	136
Software Upgrades	138
Managing System Firmware	138
Managing Drive Firmware	140
Downloading Drive Logs	143
Rebooting the Library	143
Rebooting Drives	144
Controlling the UID LED	145
Moving the Robotic Assembly to the Base Module	146
LTO-9 New Media Initialization	147

LIBRARY TESTS

System Test

The system test exercises overall library functionality by moving cartridges within the library.

- During each cycle, the library moves a cartridge from a full slot to an empty slot and then returns it to its original slot. You can select the number of cycles for the test. If the test is canceled, the library returns the cartridge to its original slot.
- The library does not move cleaning cartridges during the test.
- The test operates over the whole library and does not take into account partition configuration.
- During the test the library is offline.

To run the system test, navigate to the **Maintenance > Library Tests > System Test** screen, select the number of cycles, and then click **Start Test**.

Maintenance > Library Tests > System Test

NOTE: The System Test loads cartridges from slots into drives, then returns each cartridge to its original slot a user-specified number of times. The test requires at least one compatible cartridge for each generation of tape drive in the library. The tape drives must be empty before starting the test, and at least one slot needs to be full. For more information, see the online help.

Cycles:
Media:

Test Status

Direction : Drive (15) => Slot (7.26)
Cycles : 1 of 1
Status : Passed

Figure 73 The System Test screen.

Slot to Slot Test

The slot to slot test randomly exchanges cartridges between slots to verify that the library is operating correctly. At the end of the test, the cartridges are not returned to their original slots. If a tape is moved to an incompatible drive, the drive rejects the tape, as designed.

**CAUTION**

The test can move cartridges between partitions.

For service and diagnostics, use the [Maintaining the Library on page 127](#).

To run the slot to slot test, navigate to the **Maintenance > Library Tests > Slot to Slot Test** screen, select the number of cycles, and click **Start Test**.

Maintenance > Library Tests > Slot to Slot Test

NOTE: The Slot to Slot Test randomly exchanges cartridges between slots a user-specified number of times. The test requires at least one cartridge in any slot and at least one empty slot in the library. For more information, see the online help.

Cycles:

Test Status

Direction :

Cycles : of

Status :

Figure 74 The Slot to Slot Test screen.

Element to Element Test

The element to element test moves a selected cartridge to a selected slot or tape drive, and then returns it to the original slot. If the selected destination is a tape drive, the tape is loaded and unloaded before it is returned. You can select the number of times to move the selected cartridge to the destination location and back.

The element to element test is intended to show that the library is operating correctly. To diagnose problems with the robotic assembly or verify that it has been correctly replaced, use the [Maintaining the Library on page 127](#).

To run the element test:

1. Navigate to the **Maintenance > Library Tests > Element to Element Test** screen.

Maintenance > Library Tests > Element to Element Test

NOTE: The Element to Element Test moves cartridges between two user-defined element locations a user-specified number of times. The test requires at least one cartridge. If moving a cartridge to or from a tape drive, the cartridge must be compatible with the generation of the tape drive. One of the selected element locations must be empty, and one of the selected element locations must be full, before starting the test. For more information, see the online help.

Filter On
All

Source Elements				Destination Elements			
Element	Barcode	Module	Part.	Element	Status	Module	Part.
Mailslot (7.38)	CLN012L1	7	1	Mailslot (1.37)		1	1
Mailslot (7.39)	000113L5	7	1	Mailslot (1.38)		1	1
Drive (1)	TC094ML5	1	1	Mailslot (1.39)		1	1
Drive (3)	TC084ML5	1	1	Mailslot (1.40)		1	1
Drive (6)	TD239ML4	2	1	Mailslot (2.36)		2	1
Slot (7.3)	TC070ML5	7	1	Mailslot (2.37)		2	1
Slot (7.25)	000112L5	7	1	Mailslot (2.38)		2	1
Slot (7.26)	000118L5	7	1	Mailslot (2.39)		2	1
				Mailslot (2.40)		2	1
				Mailslot (3.36)		3	1
				Mailslot (3.37)		3	1
				Mailslot (3.38)		3	1
				Mailslot (3.39)		3	1
				Mailslot (3.40)		3	1
				Mailslot (4.36)		4	1
				Mailslot (4.37)		4	1
				Mailslot (4.38)		4	1
				Mailslot (4.39)		4	1

Selected Source: _____ Selected Destination: _____

Cycles: Test Status

Direction : _____

Cycles : _____ of _____

Status : _____

Figure 75 The Slot to Slot Test screen.

2. Select a cartridge from the Source Elements list.

To view a subset of the cartridges by barcode:

- a. Click **Filter On**.
- b. Enter characters into the search box and then click **Search**.

The Source Elements list is updated to only include cartridges with barcode labels including the search characters.

3. Select a location from the Destination Elements list.
4. Using the drop-down menu, select the number of **Cycles**.
5. Click **Start Test**.

Position Test

The Position Test moves the robotic assembly vertically between two selected elements. The test does not move cartridges.

1. To run the position test, navigate to the **Maintenance > Library Tests > Position Test** screen.

Maintenance > Library Tests > Position Test

NOTE: The Position Test moves the robotic assembly vertically between two element locations a user-specified number of times. The test does not move cartridges. For more information see the online help.

Source Elements				Destination Elements			
Element	Barcode	Module	Part.	Element	Barcode	Module	Part.
Mailslot (1.37)		1	1	Mailslot (1.37)		1	1
Mailslot (1.38)		1	1	Mailslot (1.38)		1	1
Mailslot (1.39)		1	1	Mailslot (1.39)		1	1
Mailslot (1.40)		1	1	Mailslot (1.40)		1	1
Mailslot (2.36)		2	1	Mailslot (2.36)		2	1
Mailslot (2.37)		2	1	Mailslot (2.37)		2	1
Mailslot (2.38)		2	1	Mailslot (2.38)		2	1
Mailslot (2.39)		2	1	Mailslot (2.39)		2	1
Mailslot (2.40)		2	1	Mailslot (2.40)		2	1
Mailslot (3.36)		3	1	Mailslot (3.36)		3	1
Mailslot (3.37)		3	1	Mailslot (3.37)		3	1
Mailslot (3.38)		3	1	Mailslot (3.38)		3	1
Mailslot (3.39)		3	1	Mailslot (3.39)		3	1
Mailslot (3.40)		3	1	Mailslot (3.40)		3	1
Mailslot (4.36)		4	1	Mailslot (4.36)		4	1
Mailslot (4.37)		4	1	Mailslot (4.37)		4	1
Mailslot (4.38)		4	1	Mailslot (4.38)		4	1
Mailslot (4.39)		4	1	Mailslot (4.39)		4	1

Selected Source: Selected Destination:

Cycles: Test Status

Direction :
 Cycles : of
 Status :

Figure 76 The Position Test screen.

2. Select one element from the Source Element list and another from the Destination Element list.
3. Using the drop-down menu, select the number of **Cycles**, and click **Start Test**.

Wellness Test

The wellness test performs a general health check on the library functionality by running the following tests:

- Basic Hardware Review
- Robotics Initialization Test
- Barcode Scanning Test
- Magazine/EE Port Unlock Motor Test
- Move Media Test

Keep the following in mind when running the Wellness test:

- Running the test requires at least one drive and one tape cartridge in the library.
- After the test has started, the **Stop Test** button is active. Clicking **Stop Test** aborts the wellness test, but not before the current test has completed.
- The test operates over the entire library and does not take into account partition configuration.
- During the test the library is offline.
- The Info column notifies the user of the status and result of each test.

To run the system test, navigate to the **Maintenance > Library Tests > Wellness Test** screen, and then click **Start Test**.

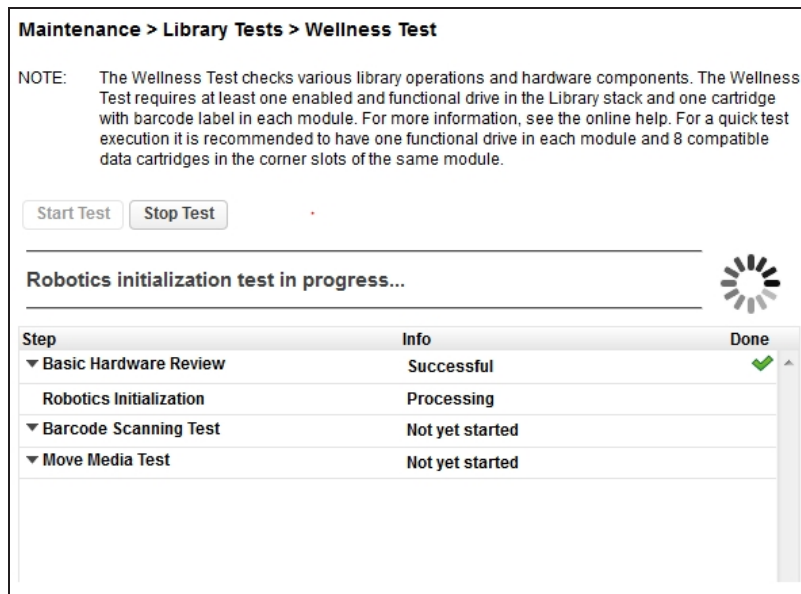

Figure 77 The Wellness Test screen.

Robotics Test

The robotics test performs a full inventory and exercises all robotic assembly movements and sensors.

To run the robotics test, navigate to the **Maintenance > Library Tests > Robotic Test** screen, then click **Start Test**.

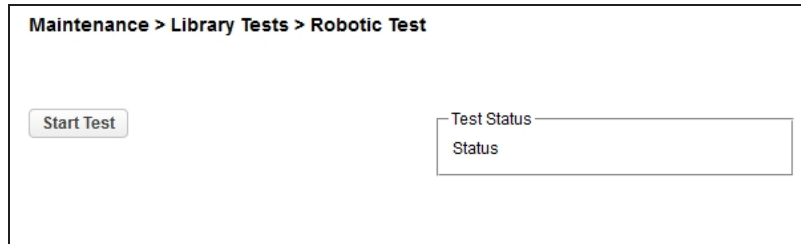

Figure 78 The Robotic Test screen.

OCP Test and Calibration

1. To test or calibrate the OCP, navigate to the **Maintenance > Library Tests > OCP Test** screen.

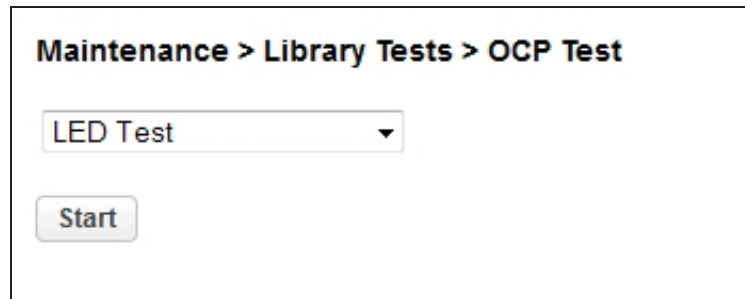

Figure 79 The OCP Test screen.

2. Select the desired test:
 - LED test - illuminates each of the front panel LEDs
 - Touch panel calibration test - allows you to calibrate the LCD touch screen
 - OCP reboot - reboots the LCD touch screen
3. Click **Start**.
4. Follow the instructions on the screen.

LOGS AND TRACES

Viewing Log Files

To view the library log files, navigate to the **Maintenance > Logs and Traces > View Logs** screen and then select one of the logs. The available logs are:

- Event Ticket Log - Records library error and warning events
- Information Log - Records library information warnings
- Configuration Log - Records configuration changes

Maintenance > Logs and Traces > View Logs

Event Ticket Log

Close all open tickets Clear log Include closed tickets Event Ticket Log ▾

Total (22)

Ticket-No	Time	Event	Description	State	Component	Component ID	Severity
27	21.11.2018 15:37:25	4012	Move cartridge operation failed due to drive or media issue	Singular	Drive	1 (7)	WARNING
26	21.11.2018 15:31:58	4005	Drive is reporting a critical TapeAlert	Resolved	Drive	1 (7)	WARNING
25	21.11.2018 15:31:58	4065	A tape alert flag was reported by a drive	Resolved	Drive	1 (7)	WARNING
24	21.11.2018 15:31:58	4065	A tape alert flag was reported by a drive	Resolved	Drive	1 (7)	WARNING
23	21.11.2018 15:03:12	4021	Drive has been hot removed while in active status as data transfer device	Resolved	Drive	2 (8)	WARNING
22	21.11.2018 13:45:49	4065	A tape alert flag was reported by a drive	Resolved	Drive	3 (10)	WARNING
21	21.11.2018 13:45:49	4065	A tape alert flag was reported by a drive	Resolved	Drive	3 (10)	WARNING
20	21.11.2018 13:45:49	4065	A tape alert flag was reported by a drive	Resolved	Drive	3 (10)	WARNING

Figure 80 The View Logs screen.

The log entries are displayed in order of most recent to oldest. The log entries contain a date and time code, event code, severity, component identifier, and event details. The format for the date and time is: *YY.MM.DD HH.MM.SS.ss*.

- *YY.MM.DD* - The date displayed as Year.Month.Day
- *HH.MM.SS.ss* - The time displayed as Hour.Minute.Second.Hundredths of a second

Downloading Log and Trace Files

To download the library log and trace files from the RMI, navigate to the **Maintenance > Logs and Traces > Download Logs and Traces** screen and click **Save**.



Figure 81 The Download Logs and Traces screen.

Configuring Remote Logging

If desired, you can configure remote logging to send system messages to a remote logging server.

1. From the home screen of the library interface, select **Configuration**. The Configuration screen displays.
2. Select **Network Management**, then select **Remote Logging (rsyslog)**. The Remote Logging (rsyslog) screen displays.

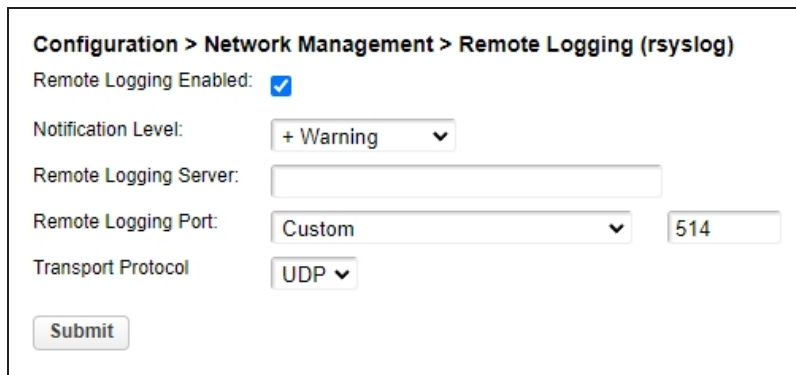

Figure 82 The Remote Logging (rsyslog).

3. Select or clear **Remote Logging Enabled**.

- Using the **Notification Level** drop-down menu, select the notification level you want to receive.

Selection	Description
Inactive	No events are sent to the syslog server.
Critical	All critical events are sent to the syslog server.
+ Warning	Critical and warning events are sent to the syslog server.
+ Configuration	Critical, warning, and configuration events are sent to the syslog server.
+ Information	All events are sent to the syslog server.

- Enter an IP address for the **Remote Logging Server**.
- Using the **Remote Logging Port** drop-down menu, select to use the **Default** port, or to set a **Custom** port. The default port is 514.
- If you selected Custom in [Step 6](#), enter the port number.
- Using the **Transport Protocol** drop-down menu, select either **UDP** or **TCP** as the transport protocol.
- Click **Submit**.

SOFTWARE UPGRADES

Managing System Firmware

Check the Library Firmware Version

The firmware version currently installed on the library is displayed in the library status area on the Home page.

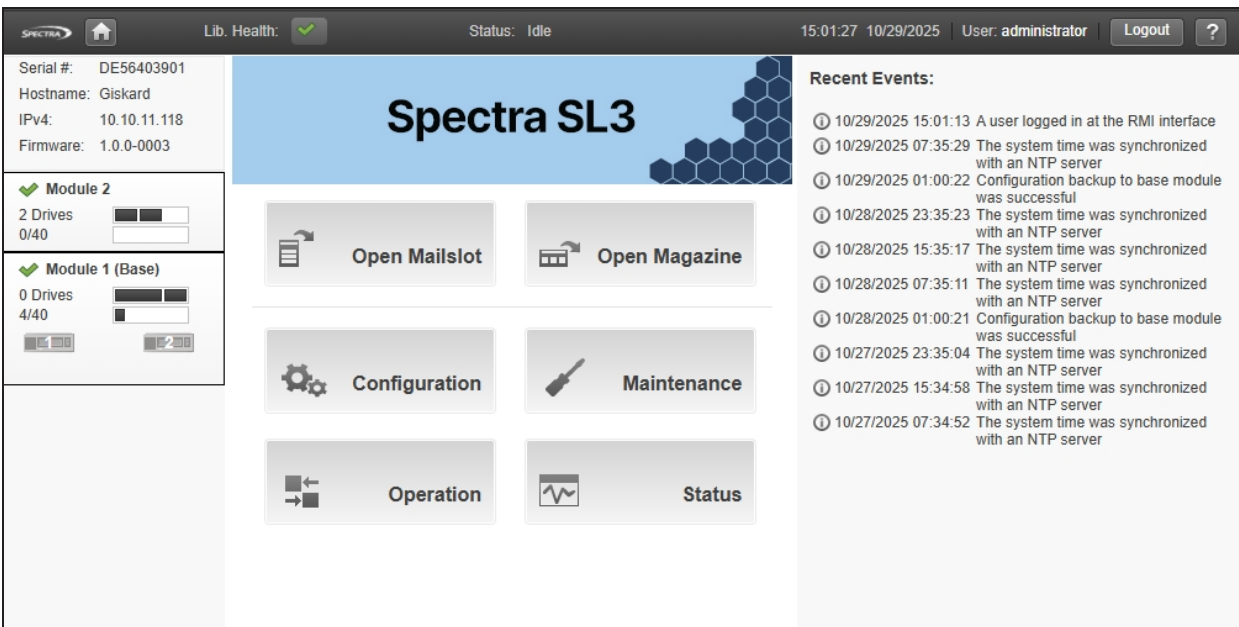

Figure 83 Spectra SL3 main screen.

Check and Download the Currently Released BlueVision Version

Follow these steps to check the currently recommended BlueVision version:

1. Log into your user account on the Technical Support portal at support.spectralogic.com.

Note: See Technical Support on page 186 for information about creating an account and accessing the Technical Support portal.

2. Select **Downloads > Product Software**.
3. On the Product Software page, locate your library type in the **Spectra Product** column. The currently released BlueVision version is listed in the **Current Version** column.

Tape Libraries				
Spectra Product	Zipped Version <i>(Use this file if you are upgrading from a version below 12.07.02.)</i>	Digitally Signed Version <i>(Use this file if you are upgrading from version 12.07.02 or higher.)</i>	File Size (KB)	Release Notes
TFinity	BlueScale12.7.00.06-20170620F.hpz	N/A	<i>Please contact Support for this update</i>	TFinity Library Release Notes and Documentation Updates
T950	BlueScale12.7.02-20170623F.2lpz	BlueScale12.7.02-20170623F.2lps	72,977/8	T950 Library Release Notes and Documentation Updates
T200/380/680	BlueScale12.6.45.3-20151121F.2boz	N/A	42,540	Spectra T200, T380, & T680 Release Notes and Documentation Updates
T120	BlueScale12.7.03-20170726F.2spz	BlueScale12.7.03-20170726F.2sps	48,929	T120 Library Release Notes and Documentation Updates
T50e	BlueScale12.7.03-20170726F.52z	BlueScale12.7.03-20170726F.52s	18,711	T50e Library Release Notes and Documentation Updates

Figure 84 The Product Software screen (T950 library firmware shown).

4. Compare the Current Version available for the library to the version installed on the library.
5. If there is a new version of the library firmware, click the name of the BlueVision package. The package begins downloading through your web browser.

Upload Library Firmware

You upload the library firmware from the **Maintenance > Firmware Upgrades > System Firmware** screen.

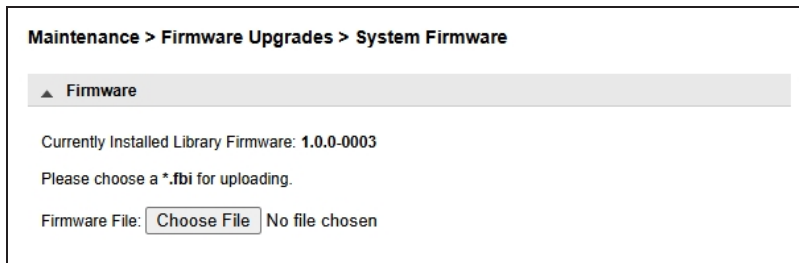

Figure 85 The System Firmware screen.

To update library firmware from the RMI:

1. Use your web browser to select the firmware file from the local computer.
2. Click **Start Upgrade**. The update process starts immediately and cannot be canceled.

To update the library firmware from the OCP:

1. Copy the firmware file to a USB device.
2. Insert the USB device into the USB port on the front of the library.
The library detects the USB device.

3. Select the firmware file.
4. Click **Start Upgrade**. The update process starts immediately and cannot be canceled.

When you update the library firmware, the library updates the firmware of the expansion modules to a compatible version.

Managing Drive Firmware

Drive firmware can be updated on multiple drives of the same type at the same time. Drive firmware can only be updated from the RMI. Each drive will only accept appropriate firmware.

Check the Drive Firmware Version

To see the firmware version currently installed on the drives, navigate to the **Status > Drive Status** screen.

The screenshot displays the 'Status > Drive Status' interface. It features a table of drive information and a detailed view for the selected drive (Drive 1).

Drive ID	S/N	Model	Status	Media	Power
1	11C48BE0DD	IBM LTO 6 HH FC	✓	Empty	On
2	11C48BE10F	IBM LTO 6 HH SAS	✓	Empty	On

Vendor: IBM		Personality: 00 14	
Firmware:	G9P1	Manufacturer S/N:	10WT007466
Powered:	On	WWNN:	5000E111C48BE0DD
Temperature:	36 °C	Partition:	2 (Library LUN)
Encryption:	Disabled	Cartridge:	N/A
IP Address:	N/A	Media Removal:	Allowed
Module Loc:	1	Data Compression:	Enabled
Cooling Fan Status:	Active	Product ID:	ULTRIUM-HH6

Port A Status (WWPN: 5000E111C48BE0DE)

Speed:	4 Gb/s	Port Type:	Loop (L)
Interface:	Login complete	Loop ID / ALPA:	0x6F / 0x26

Buttons: Refresh, Expand All

Figure 86 The Drive Status screen.

Check and Download the Currently Released Drive Firmware

Download the recommended drive firmware from the Spectra Logic Technical Support portal, and save it to your local computer.

1. Log into your user account on the Technical Support portal at support.spectralogic.com.

Note: See [Technical Support](#) on page 186 for information about creating an account and accessing the Technical Support portal.

2. Select **Downloads > Drive Firmware**.
3. On the Tape Drive Firmware page, locate the appropriate drive firmware with respect to drive type (LTO), generation (for example, LTO-6), interface type (for example, SAS or Fibre), and form factor (half-height).

LTO-7 <i>(IBM TotalStorage 3580 Ultrium 7)</i>					
Technology	Form Factor	Current FW File (use with ITDT)	File Size (KB)	Zipped Package File (for staging) <i>Use this file if your library is at a BlueScale version below 12.07.02.</i>	Digitally Signed Package File (for staging) <i>Use this file if your library is at BlueScale 12.07.02 or higher.</i>
Fibre Channel	Full-Height	LTO7_G9Q0.fcp_fh.fmrz	12,142	IBM-LTO7-FH-Fibre_G9Q0-20161005D.dlz	IBM-LTO7-FH-Fibre_G9Q0-20161005D.dls
Fibre Channel	Half-Height	LTO7_G9Q1.fcp_hh.fmrz	12,165	IBM-LTO7-HH-Fibre_G9Q1-20161005D.dlz	IBM-LTO7-HH-Fibre_G9Q1-20161005D.dls
SAS	Half-Height	LTO7_G9Q1.sas_hh.fmrz	12,086	IBM-LTO7-HH-SAS_G9Q1-20161005D.dlz	IBM-LTO7-HH-SAS_G9Q1-20161005D.dls

IBM LTO-7 Drive Firmware Release Notes

Figure 87 A portion of the Tape Drive Firmware page.

4. Click the firmware version name in the column labeled **Current FW File**.
 - Note:** While the column header references that the file is for “use with ITDT”, the file is also compatible with your Spectra SL3 library.
5. Use your web browser’s download features to save the file.

Update Drive Firmware

1. Navigate to the **Maintenance > Software Upgrades > Drive Firmware** screen. The tape drives are organized by drive type.

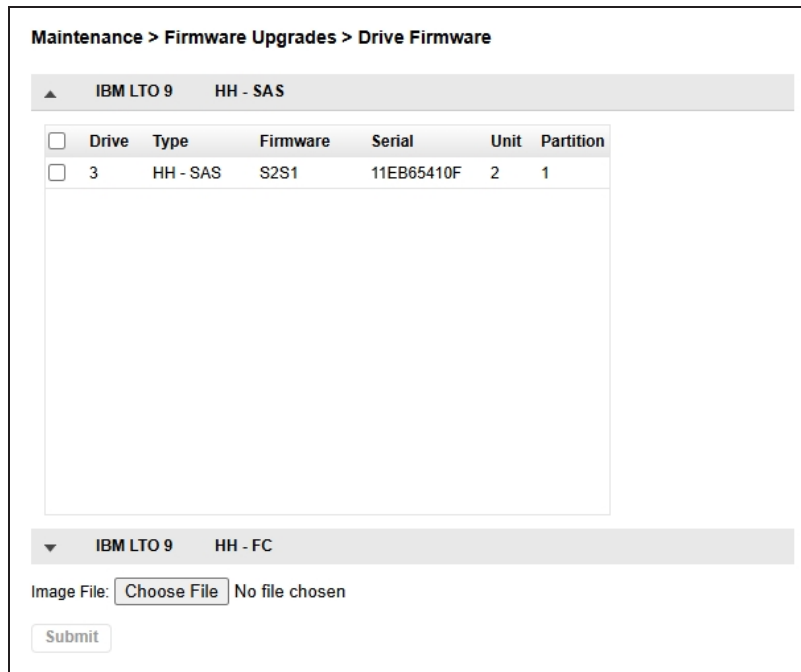

Maintenance > Firmware Upgrades > Drive Firmware

▲ IBM LTO 9 HH - SAS

<input type="checkbox"/>	Drive	Type	Firmware	Serial	Unit	Partition
<input type="checkbox"/>	3	HH - SAS	S2S1	11EB65410F	2	1

▼ IBM LTO 9 HH - FC

Image File: No file chosen

Figure 88 The Drive Firmware screen.

2. Expand the appropriate drive type and select one or more tape drives.
3. Click **Browse** and use your web browser to select the firmware file.
4. Click **Submit**.

DOWNLOADING DRIVE LOGS

To download a drive log from the RMI:

1. Navigate to the **Maintenance > Download Drive Logs** screen.

Maintenance > Download Drive Logs

▲ Drive Logs

Forced Dump ▼

Drive	Type	Firmware	Serial	Module	Partition	
<input checked="" type="checkbox"/>	1	IBM - LTO6 - HH - FC	G9P1	11C48BE0DD	1	2
<input type="checkbox"/>	2	IBM - LTO6 - HH - SAS	H991	11C48BE10F	2	1

Save ...

Figure 89 The Download Drive Logs screen.

2. Select the drive(s) from which you want to collect logs.
3. Select the type of log to collect (Regular Dump or Forced Dump).
4. Click **Save**.

REBOOTING THE LIBRARY

From the **Maintenance > System Reboot** screen, click **Reboot**.

Maintenance > System Reboot

Reboot

Figure 90 The System Reboot screen.

REBOOTING DRIVES

1. From the **Maintenance > Drive Reboot** screen, select the drive(s) you want to reboot and click **Submit**.

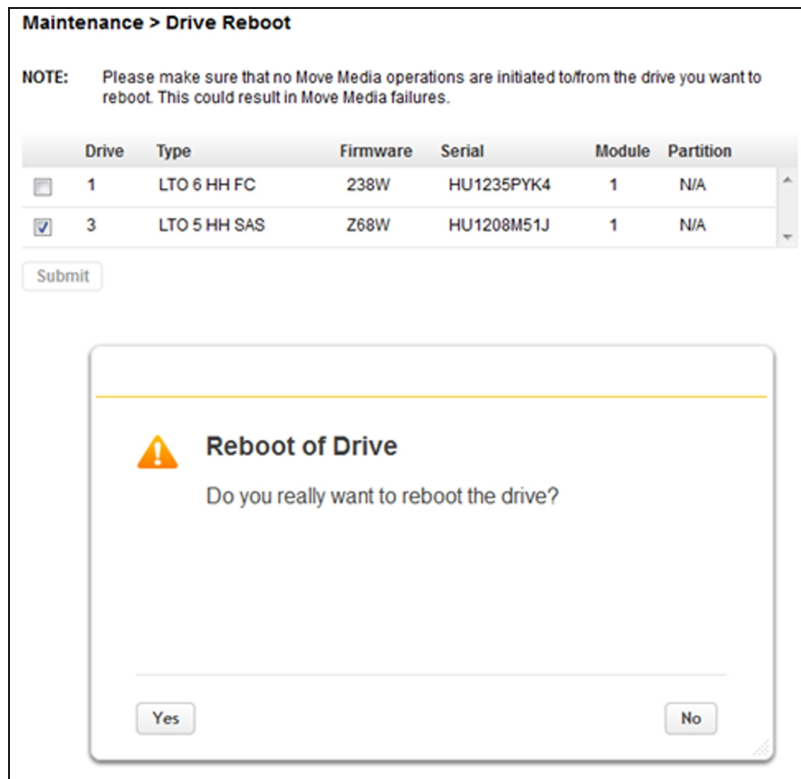

Figure 91 The Drive Reboot screen.

2. Click **Yes** on the dialog popup to start the reboot process.

CONTROLLING THE UID LED

The UID LEDs are a pair of blue LEDs - one on the OCP and the other on the controller module controller. The UID LEDs are useful for identifying the library in a data center. The UID LEDs are operated synchronously and controlled by the user. You can see if the LEDs are lit, and toggle the status from the **Maintenance > UID LED Control** screen.

Maintenance > UID LED Control

NOTE: UID LEDs are intended to assist users or service personnel in determining which component needs attention. This page allows you to control the UID LED for specific components.

▲ **Component Drive**

<input type="checkbox"/> Select All	Drive	Module	Type
<input type="checkbox"/>	9	4	HP LTO7 HH SAS
<input type="checkbox"/>	10	4	IBM LTO7 HH SAS
<input type="checkbox"/>	11	5	HP LTO7 HH FC
<input type="checkbox"/>	12	5	HP LTO7 HH SAS
<input type="checkbox"/>	13	5	HP LTO7 HH SAS
<input type="checkbox"/>	14	6	IBM LTO7 HH SAS
<input type="checkbox"/>	15	6	HP LTO7 HH FC
<input type="checkbox"/>	16	6	HP LTO7 HH FC

▲ **Component Controller**

<input type="checkbox"/> Select All	Module	Type
<input type="checkbox"/>	1	Expansion Controller
<input type="checkbox"/>	2	Expansion Controller
<input type="checkbox"/>	3	Expansion Controller
<input type="checkbox"/>	4	Base Controller + Operator Control Panel
<input type="checkbox"/>	5	Expansion Controller
<input type="checkbox"/>	6	Expansion Controller

Figure 92 The Maintenance > UID LED Control screen.

MOVING THE ROBOTIC ASSEMBLY TO THE BASE MODULE

Before extending a module from the rack, the robotic assembly must return to its park position in the base module. Under normal circumstances, when the library is powered off using the front power button, the robot automatically parks and locks into the controller module behind the OCP. After powering off the library and before proceeding with extending a module from the rack, look inside the base module window to verify that the robotic assembly is behind the OCP.

Use the following instruction if the library did not move the robotic assembly to its park position:

1. Power on the library.
2. Log into the library as an Administrator user.
3. Navigate to the **Maintenance > Move Robotic to Base Library** screen.

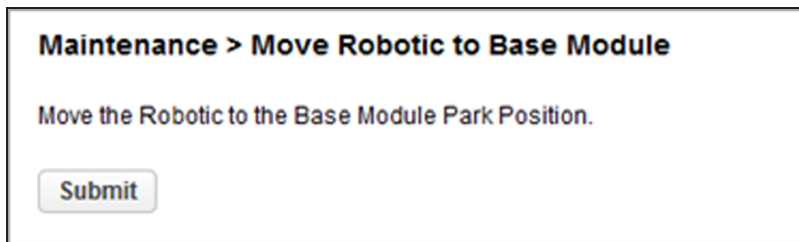

Figure 93 The Move Robotic to Base Module screen.

4. Click **Submit**.

If the robot still did not park and locks into the base module, contact Spectra Logic Technical Support. See [Contacting Spectra Logic](#) on page 8.

LTO-9 NEW MEDIA INITIALIZATION

The LTO-9 cartridge initialization includes a media calibration process that increases the initialization time to up to two hours per cartridge. To assist with this, you can use this wizard to start a bulk initialization of LTO-9 cartridges in the tape library.



IMPORTANT

After the LTO-9 New Media Initialization starts, it is possible to abort the process; however, any media that has been loaded into a drive **MUST** complete its initialization before the wizard aborts and the processing of remaining media stops. Shutting down the initialization process can take up to two hours.



IMPORTANT

All Spectra Certified LTO-9 media is initialized before it ships and does not need to go through this process.

Use the instructions below to initialize LTO-9 media using the LTO-9 New Media Initialization Wizard.

1. Navigate to the **Maintenance > LTO-9 New Media Initialization Wizard** screen. The LTO-9 New Media Initialization Wizard screen displays.

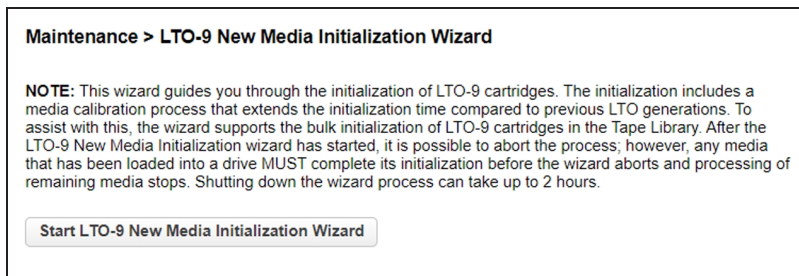

Figure 94 The LTO-9 New Media Initialization Wizard screen.

2. Click **Start LTO-9 New Media Initialization Wizard**. The Information screen displays.



Figure 95 The Information screen.

3. Read the note for the wizard and click **Next**. The Select Cartridges screen displays.

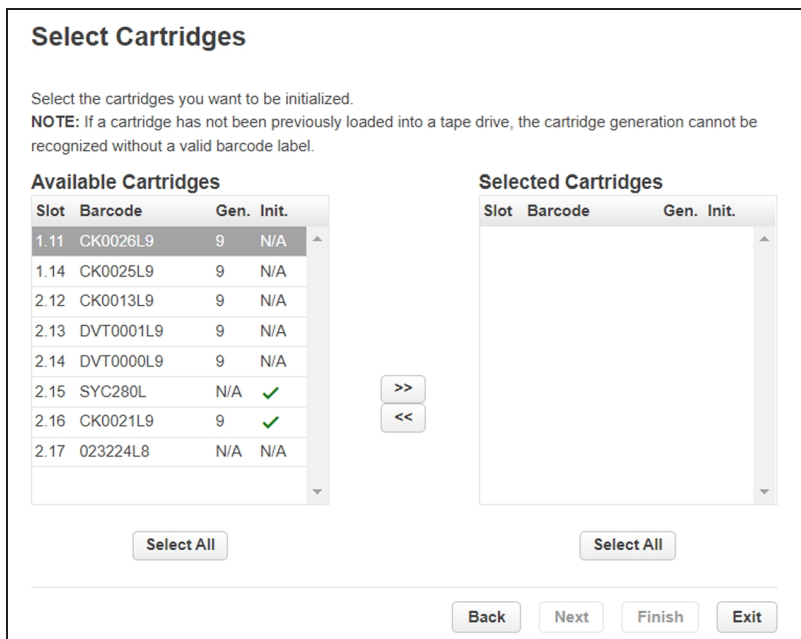

Figure 96 The Select Cartridges screen.

4. Select the LTO-9 cartridges that you want to initialize and click >> to move them to the Selected Cartridges column. When all of the cartridges that you want initialized are in the Selected Cartridges column, click **Next**. The Select Drives screen displays.

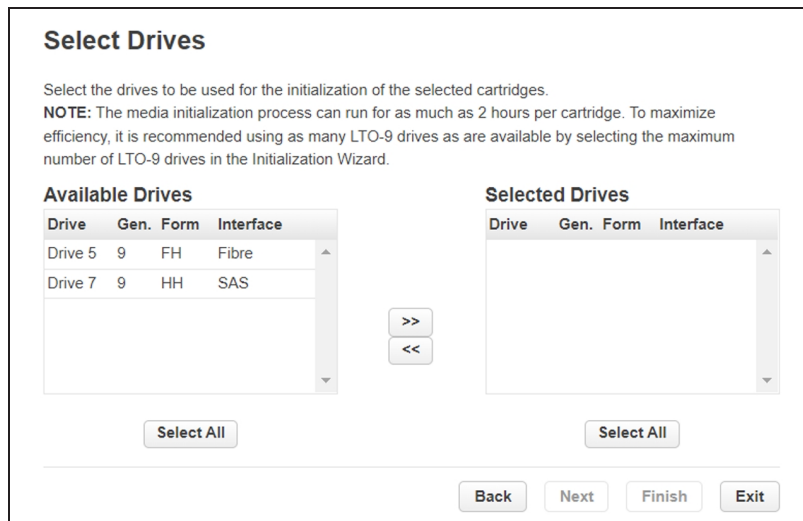

Figure 97 The Select Drives screen.

5. Select the LTO-9 drives that you want to use to initialize the cartridges and click >> to move them to the Selected Drives column. To maximize efficiency, select as many LTO-9 drives as possible. When all of the drives that you want to use to initialize cartridges are in the Selected Drives column, click **Next**. The Finish screen displays.

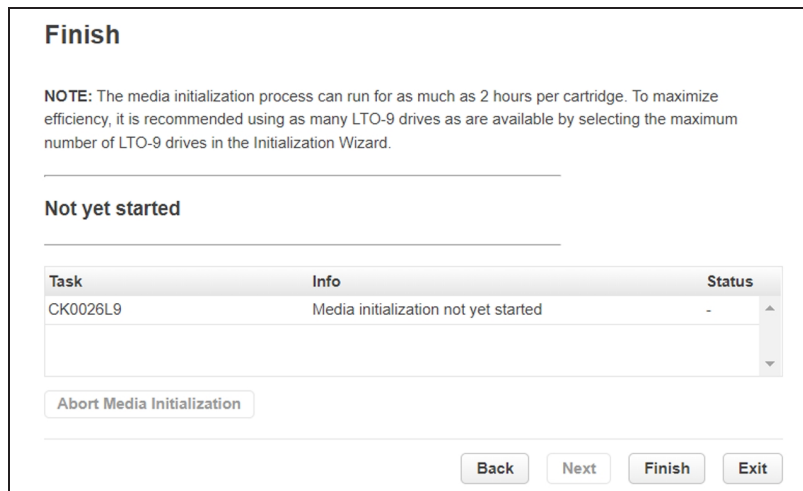

Figure 98 The Finish screen.

6. Click **Finish**. The initialization process begins.
7. If necessary, click **Abort Media Initialization** to stop initializing cartridges before all cartridges are initialized; however, any media that has been loaded into a drive **MUST** complete its initialization before the initialization aborts and the processing of remaining media stops. Shutting down the wizard process can take up to two hours.

CHAPTER 7 - LIBRARY TROUBLESHOOTING



CAUTION

This library is designed to operate when installed in a rack using the rack rail kit. Operating the library without installing it in the rails, such as on a table or rack shelf, may result in library errors. Placing any weight on top of the library might also cause errors.

Fibre Channel Connection Problems	151
Detection Problems after Installing a SAS Drive	152
Operation Problems	154
Power Problems	154
Failure/Attention Indications Displayed on the Operator Control Panel	154
Tape Movement Problems	155
Media Problems	155
Attention LED is Lit	156
Inventory Problems	157
RMI Network Connection Issues	157
Performance Problems	159
Average File Size	159
File Storage System	159
Connection from the Backup/Archive Host Server to a Disk Array	160
Backup/Archive Server	160
Backup/Archive Software and Method	160
Connection from the Archive/Backup Host Server to the Library	161
Media	161
Finding Event Information	161
Unlocking the Magazine	162
Using the OCP or RMI	162
Using the Manual Release	163
Unloading a Stuck Tape	163
Identifying a Failed Component	164

FIBRE CHANNEL CONNECTION PROBLEMS

Use the **Status> Drive Status** screen to check the link connection for your tape drive.

If the screen shows **Logged Out**:

- Check that the Fibre speed is set to **Automatic** or that the correct Fibre speed is selected. If you are unsure of the speed of the HBA or switch that the drive is connected to, select **Automatic**.
- Check that the correct port type, fabric or loop, is selected. Loop requires additional configuration. If you are unsure of the correct port type, select **Automatic**.

If the screen shows **No Link**, the **Speed Status** displays the '-' character, and the **Link LED on the back of the drive is off**:

- The speed is probably set incorrectly. Try setting the speed to **Automatic**.
- If there are still issues, change the port type to **Auto Detect**.

If the screen shows **No Light**:

- The cable is not plugged in correctly. Check that it is connected correctly to Port A of the tape drive.
- The cable is damaged. FC cables are delicate. If the cable has been bent or twisted sharply, it might be broken and must be replaced.

If the screen shows **ALPA Conflict**:

- There might be a conflict with the ALPA address on Loop ports. Select **Soft** for the Loop mode to allow the system to select an available address each time the tape drive connects to the FC fabric. If your server configuration does not support changing addresses, try using the **Hard Auto-Select** option for the Loop mode. This allows the system to select an available address when it first connects, and then retain that address for future connections.

DETECTION PROBLEMS AFTER INSTALLING A SAS DRIVE

Problems encountered after installation are often caused by improper SAS cable connections, storage management software configuration errors, or operating system configuration errors. If the storage management software or operating system does not communicate with the library after installation, determine the extent of the detection problem:

- Does the storage management software detect the tape drive?
- Does the storage management software detect the library?
- Does the operating system detect the tape drive?
- Does the operating system detect the library?
- Does the operating system detect the library, but list it as a generic device?

Based on the extent of the detection problem, check the following:

- If neither the storage management software nor operating system detects the tape drive, or they do not detect both the tape drive and the library:
 - Verify that all SAS cables are securely connected at both ends.
 - Check the length and integrity of your SAS cabling. For reliable operation, do not use a SAS cable longer than six meters. Do not use a cable adapter or converters between the HBA and the library.
 - Check the SAS connectors for damage or debris.
 - Verify that your HBA is supported by the host computer and qualified with the library.
 - Verify that your HBA has the latest firmware.
- If the storage management software or operating system detects the tape drive, but not the library:
 - Verify that multiple LUN support is enabled on the HBA. The library uses two Logical Unit Numbers (LUNs) to control the tape drive (LUN 0) and robotic assembly (LUN 1). The library requires an HBA with multiple LUN support and multiple LUN support must be enabled on the host computer. When multiple LUN support is disabled, the host computer can see the tape drive, but not the library.

Note: Many RAID or array controllers do not provide multiple LUN support.

- If the storage management software or operating system does not detect any devices on the HBA:
 - Verify that the SAS host adapter is installed correctly. Refer to the manual that came with your host adapter for installation and troubleshooting instructions.
 - Verify that the proper device driver is installed for the SAS host adapter.
- If the library is detected by the operating system, but not by the storage management software:

- Refer to the documentation included with your storage management application for instructions on how to verify proper installation. Some backup software packages require an additional driver to communicate with the robotics.
- If the library is detected by the operating system, but is listed as an unknown or generic device:
 - Make sure that the proper device driver, if applicable, is installed for the library. Check your storage management software provider's website for the latest drivers and patches.

If you continue to have problems with a SAS library, check the following:

- Ensure that the library is compatible with the SAS host adapter and storage management software you plan to use.
- Verify that your HBA is supported by the host computer and qualified with the library.
- Ensure you are using a compatible, high-quality cable.

OPERATION PROBLEMS

Power Problems

Problem	Solution
Library does not power on	<ol style="list-style-type: none"> 1. Check all power cord connections. 2. Check the LEDs on the power supplies. 3. Make sure the power button on the front panel has been pressed, and the green Ready LED is lit. 4. Make sure the outlet has power. Try another working outlet. 5. Replace the power cord.
No message appears on the OCP display	<ol style="list-style-type: none"> 1. Check all power cord connections. 2. Check the LEDs on the power supplies. 3. Make sure the power button on the front panel has been pressed, and the green Ready LED is lit. 4. Make sure the outlet has power. Try another working outlet.

Failure/Attention Indications Displayed on the Operator Control Panel

If the problem persists, contact Spectra Logic Technical Support. See [Contacting Spectra Logic on page 8](#).

Problem	Solution
The OCP displays a warning or error icon	Click the icon to see more information about the event on the OCP.
The OCP displays an error code	Look up the error code, try to resolve the failure, and power cycle the library (see Event Codes on page 165).

Tape Movement Problems

Problem	Solution
<p>Tape stuck in drive</p>	<p>Try the following steps, in this order, to remove the stuck tape.</p> <p>Note: The tape drive must rewind the tape before ejecting it. This can take as long as five minutes, depending on how much tape must be rewound. Once the tape is rewound, the eject cycle takes approximately 15 seconds.</p> <p>The Ready light flashes while the tape rewinds. Wait for the tape to finish rewinding before attempting another operation.</p> <ol style="list-style-type: none"> 1. Attempt to unload the tape from your backup software. 2. Shut down the storage management software and stop the operating system's removable storage services. From the Operation > Move Media screen, attempt to unload or move the tape to a slot. 3. Power down the library and disconnect the cable from the drive. Power up the library, and wait until the tape drive is idle or ready. From the Operation > Move Media screen, attempt to unload or move the tape to a slot. 4. From the Operation > Force Drive Media Eject screen, attempt to force eject the tape . <p>IMPORTANT  Inspect the tape cartridge. Damage or misplaced labels on the cartridge may have caused the load/unload failure. Discard any tape cartridge found to have issues.</p>
<p>Tape cannot be removed from storage slot</p>	<ol style="list-style-type: none"> 1. Unlock the magazine from the Operation > Open Magazine screen and extend it to access the storage slot. 2. Grasp the cartridge and remove it from the storage slot. Some tapes need to be inserted and removed several times to condition them for free movement in and out of the magazine. 3. Check the barcode label and verify that it is secure to the cartridge. 4. Check the cartridge for damage. 5. Check the storage slot for damage.

Media Problems

Problem	Solution
<p>Cleaning or data cartridge incompatible with drive</p>	<ul style="list-style-type: none"> • Check the event log to see which cartridge is incompatible.

Problem	Solution
	<ul style="list-style-type: none"> • Make sure you are using data and cleaning cartridges that are compatible with the drive and that you are using the correct cartridge type for the operation. The drive automatically unloads incompatible cartridges, the Attention LED flashes. Export the media.
<p>Cannot write to or read from tape</p>	<ul style="list-style-type: none"> • Make sure that the cartridge is not a WORM cartridge that has already been used. • Make sure that the cartridge is write enabled (move the write-protect switch to the enabled position). • Make sure the data cartridge is compatible with the drive model. LTO-5 through LTO-7 tape drives can read data cartridges from two generations back and write to data cartridges one generation back. LTO-8 drives can read and write LTO-7 and LTO-8 tapes only. • Make sure that the cartridge has not been exposed to harsh environmental, magnetic, or electrical conditions and is not physically damaged in any way. • Many storage management applications do not read or write to cartridges that were created using a different application. In this case, you may have to perform an erase, format, or label operation on the cartridge. • Make sure you understand any data protection or overwrite protection schemes that your storage management application may be using, which could prevent you from writing to a given cartridge. • Retry the operation with a different, known good tape. • Clean the tape drive from the Operation > Clean Drive screen.

Attention LED is Lit

Problem	Solution
<p>Both the Attention and Cleaning LEDs are lit</p>	<p>This is most likely caused by a dirty drive that cannot read a tape and marks the tape invalid.</p> <p>Log into the OCP or RMI and check the event log to see which drive has reported that it needs cleaning. Clean the drive with an approved Ultrium cleaning cartridge.</p>
<p>A particular cartridge sets off the cleaning light</p>	<p>Remove the cartridge from the library.</p>

Problem	Solution
A cartridge recently imported from a different environment is causing issues	Media that is moved from one environment to another can cause issues until it has acclimated to the new conditions. A cartridge should be acclimated for at least 24 hours before use, particularly if it has been stored at a substantially different temperature or level of humidity than the library.
The Attention LED is lit but the Cleaning LED is not lit after a cartridge load	The library was unable to complete the requested operation with the selected tape cartridge. <ul style="list-style-type: none"> • Use only cartridges that are compatible with the drive type • Use the correct type of cartridges for the operation. For example, use a cleaning cartridge for cleaning. • Make sure you are using a Universal cleaning cartridge
The Cleaning LED is lit after using a cleaning cartridge	The cleaning cartridge has expired. A cleaning cartridge expires after 50 uses.
A particular cartridge sets off the Attention LED and possibly the Cleaning LED	Retry the operation with a different cleaning cartridge. If the Attention LED is cleared and the drive has been cleaned, and then immediately re-displays each time a particular cartridge is reloaded, that cartridge should be suspected as being defective. <ul style="list-style-type: none"> • If this occurs, export the cartridge and load a known good cartridge. • Any cartridge that is suspected of being defective or contaminated should NOT be reused in any drive. • If the bad cartridge is a cleaning cartridge, it might be expired.

Inventory Problems

Problem	Solution
The library displays incorrect barcodes	<ul style="list-style-type: none"> • Verify that the label is properly applied. • Verify that the label is not soiled.

RMI Network Connection Issues

Problem	Solution
Cannot connect to the RMI	<ul style="list-style-type: none"> • Verify that the Ethernet cable is connected to the controller module's controller board and to the LAN.

Problem	Solution
	<ul style="list-style-type: none"> • Verify that the link LED on the RJ45 (LAN) connector is lit when the library is powered on. If the LED is not lit, the library is not communicating with the LAN. See your network administrator for help. • Verify that the library has been configured with a valid static network address or DHCP has been enabled so the library can obtain a network address. If using DHCP, obtain the library's network address from the OCP login screen. If the library did not obtain a valid address via DHCP, verify that the DHCP server is up and the library has network access to it. If necessary, set a static network address instead. • Enter the library's IP address into the address bar of a web browser connected to the same LAN as the library. If the RMI web page does not display, ping the library's IP address. If the ping fails, verify that the library has a valid network address and that there are no firewalls or other obstructions to network traffic between the computer with the web browser and the library. See your network administrator for help.

Cleaning Problems

Problem	Solution
Cannot load the cleaning cartridge	<ul style="list-style-type: none"> • Make sure you are using an Ultrium cleaning cartridge. • Make sure the cleaning cartridge has not expired. A cleaning cartridge expires after 50 cleaning cycles. • Power cycle the library.

PERFORMANCE PROBLEMS

The storage management process involves many system components, from the files in the file system on the host computer, through the backup server, and out to the library, all managed by software running on an operating system. The storage management process only runs as fast as the slowest component in the system.

Performance issues are solved by identifying and addressing performance limitations in your system. See sections below for the following potential performance limitations:

- Average File Size below
- File Storage System below
- Connection from the Backup/Archive Host Server to a Disk Array on the next page
- Backup/Archive Server on the next page
- Backup/Archive Software and Method on the next page
- Connection from the Archive/Backup Host Server to the Library on page 161
- Media on page 161

Average File Size

The hard drive must seek to the position of a file before it can start reading. The more time the disk drive spends seeking to files, the lower the performance. Therefore, if the average file size is small, the read performance is lower.

To determine the average file size, divide the size of the backup by the number of files.

If the average file size is small (64 KB or less), consider using a sequential, image, or block backup method that backs up the whole hard drive or LUN image instead of individual files. The trade off for using one of these methods is that you might only be able to restore the entire image instead of individual files.

Note: File fragmentation also causes excessive drive seeking, which lowers performance, so ensure that files are regularly defragmented.

File Storage System

The file storage system determines the organization of the files on the disks. Using RAID controllers to spread files over multiple disks can improve performance because some disks can be seeking while others are reading. Storing files on a single non-RAID disk results in the slowest performance while storing files on a high-end disk array results in the fastest performance.

Converting standalone disks to RAID can improve performance.

Connection from the Backup/Archive Host Server to a Disk Array

The network connection between the host server and the disk array determines how much data can be transferred from the disks to the host computer at a time. A connection with insufficient bandwidth cannot provide enough data for the tape drives to write at full speed. For optimum performance, the storage subsystem must be able to provide data at the tape drive's maximum transfer rate. Backup systems using a lower speed Ethernet network should use multiple network connections.

Backup/Archive Server

The backup server must have enough RAM and processor power to transfer the files from the disk to the tape drive, in addition to running the backup or archive software, and any other processes.

Check the RAM and processor usage during a backup operation. If they are operating at capacity, adding RAM or processor capability can improve performance.

Backup/Archive Software and Method

Each backup method has its own impact on performance, depending on how well it can keep data streaming to a tape drive. In most cases, native applications don't have the features required to maximize performance for LTO tape drives. It is recommended to use a full-featured backup or archive application with this library.

File-by-file backup or archive methods provide the best restore performance if you only need to restore individual files. However, if the average file size is small, file-by-file methods significantly reduce performance.

Disk image, flash, or sequential backup methods provide the fastest performance because they back up an entire disk, partition, or LUN, which minimizes disk seeking. The disadvantage is that backup and restore operations work on an entire disk, partition, or LUN. You might not be able to back up a subset of files or restore a single file. If you can restore a single file, the restore process is slow.

Database backup performance varies based on the use model. To improve performance when backing up data from a database:

- Use specific backup agents for the database.
- Use the latest versions of the databases.
- Do not back up individual mailboxes.
- Do not back up specific records or do a record-by-record backup.
- Do not back up when the database is in heavy use.

Connection from the Archive/Backup Host Server to the Library

For the best performance, the connection from the host server to the library must have enough bandwidth to provide enough data to keep the tape drive streaming. Current LTO tape drives take advantage of some of the fastest interfaces available so the type of interface used to connect the library to the host server is not likely to be the cause of a performance issue. However, issues with cables and connectors can limit performance.

Note: Do not exceed recommended cable lengths.

Media

The type and condition of the media also affect backup performance. For best performance, use media that is the same LTO generation as the tape drives.

FINDING EVENT INFORMATION

You can find error codes by viewing log files from the **Maintenance > Logs** and **Traces > View Logs** screen or downloading support tickets from the **Maintenance > Download Support Ticket** screen. See [Viewing Log Files](#) on page 135 or [Downloading Log and Trace Files](#) on page 136.

UNLOCKING THE MAGAZINE

It is recommended that you unlock the magazine using the OCP or RMI. If these methods fail, or if a magazine needs to be removed when the power to the library is off, you can release the magazine manually. Only one magazine or EE port can be open at a time.

Note: As a best practice, perform this procedure while applications are idle. While the magazine is extended, the library robotic assembly cannot move media.

Using the OCP or RMI

1. Log in as an administrator.
2. On the Home screen, click **Open Magazine**. The Open Magazine screen displays.

Operation > Open Magazine

NOTE: Only one magazine is allowed to be removed at a time.

Module	Left		Right	
Module 7	Closed	Open	Closed	Open
Module 6	Closed	Open	Closed	Open
Module 5	Closed	Open	Closed	Open
Base	Closed	Open	Closed	Open
Module 3	Closed	Open	Closed	Open
Module 2	Closed	Open	Closed	Open
Module 1	Closed	Open	Closed	Open

Figure 99 The Open Magazine screen.

3. Click **Open** in the left or right magazine column within the module containing the magazine you want to unlock.
4. Click **Submit**. A message box indicates when the magazine has been unlocked.
5. Click **OK** to close the message. The Open Magazine screen shows that the magazine is now unlocked. Close the magazine access door after reinserting a magazine.

Note: If not removed, the magazines and the EE port relocks after 30 seconds.

Using the Manual Release

1. Open the magazine access door.
2. Insert a small flat head screwdriver or Torx driver into the appropriate magazine release hole and gently push the tab in.

**CAUTION**

Do not exert force once you encounter resistance. Doing so can damage the device.

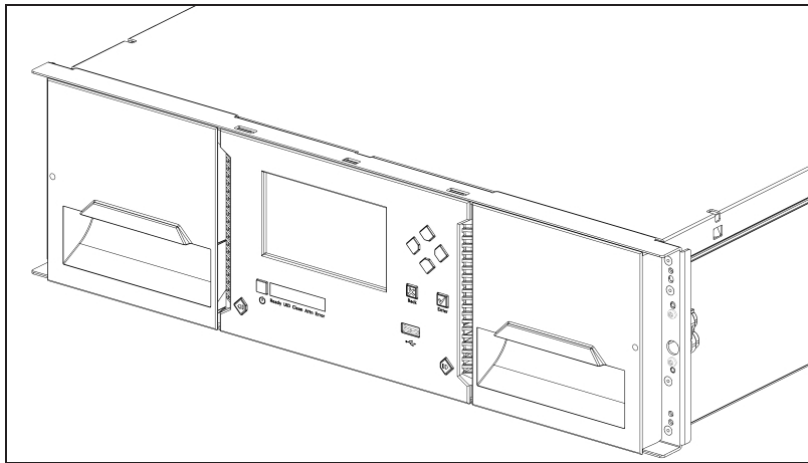

Figure 100 The magazine release.

3. Close the magazine access door after reinserting a magazine.

UNLOADING A STUCK TAPE

If a tape is stuck in a tape drive, eject the tape from the drive from the **Operation > Force Drive Media Eject** screen.

If a tape is stuck in a magazine, open the magazine (see [Library Troubleshooting on page 150](#)), grasp the cartridge, and pull it out of the storage slot.

IDENTIFYING A FAILED COMPONENT

Using the OCP or RMI:

1. If necessary, activate the UID LEDs from the **Maintenance > UID LED Control** screen. This illuminates the blue LED on the front and rear of the controller module to identify the library containing the failed module or component.
2. Identify the module within the library that contains the failed component:
 - a. In the upper left of the Home screen, locate the module that indicates an error.
 - b. Click the module for information on the failed component.

CHAPTER 8 - EVENT CODES

This chapter provides descriptions and possible solutions for error event codes.

Error Events	166
Warning Events	176
Configuration Change Events	182
Informational Events	184

ERROR EVENTS

Event Code	Message Text and Description	Details and Solution
2000	Failed to move cartridge.	Verify the source and destination elements and retry the move operation.
2002	The initial module discovery (detection of expansion modules) failed.	Verify that all expansion modules are powered on and that the expansion interconnect cables are properly installed.
2003	The library's temperature has exceeded the critical limit.	<ol style="list-style-type: none"> 1. Verify that the chassis fan in each module is functioning 2. Verify that the drive cover plates are installed in all open drive bays. 3. Verify that all power supplies are installed and working properly. 4. Verify that the ambient room temperature is within specified limits.
2004	Library startup failed.	<ol style="list-style-type: none"> 1. If the robotic assembly fails to move through a certain area of the library: <ul style="list-style-type: none"> • Look through the window in the front panel and see if there are any obstructions. • Verify that both magazines in that module can be extended. 2. Verify that all modules have power and that any expansion modules are cabled correctly with the expansion interconnect cables. 3. Verify that the top and bottom cover plates are properly installed on the library. 4. Verify that the module alignment mechanisms at the rear of the library are locked in the proper positions.

Event Code	Message Text and Description	Details and Solution
		<ol style="list-style-type: none"> 5. Reboot the library. 6. If the robotic assembly moves front to back, but not vertically, the robot shipping lock could be positioned incorrectly and should be moved to either the fully locked or fully unlocked position. <p>If the robotic assembly does not unlock the shipping lock after reboot:</p> <ol style="list-style-type: none"> 1. Move the robotic assembly to the base from the Maintenance > Move Robotic to Base module screen. See Maintaining the Library on page 127. 2. Power off the library. 3. Remove all cables from the controller module and unlock the alignment mechanism. 4. Extend the controller module from the rack. 5. Reposition the lock. <p>Note: If the error persists, review library events for additional information. See Maintaining the Library on page 127.</p>
2005	Robotic spooling cable failure.	Ensure that the spooling cable is fully seated in the controller module and correctly connected to the robotic assembly.
2009	Library test failed due to robotic assembly problem.	Review the test requirements and retry the test. If the test continues to fail, check for robotics obstructions or other robotics problems.
2010	Library test failed due to spooling mechanism defect.	Ensure that the spooling mechanism is fully seated in the controller module and installed correctly with the robotic assembly.

Event Code	Message Text and Description	Details and Solution
2011	Drive power board has failed. Some drives might be powered off.	<ol style="list-style-type: none"> 1. Ensure that the drive power boards are fully seated in the module. 2. Power cycle the library.
2012	Multiple bottom covers detected.	Remove all bottom covers except for the bottom module in the library.
2013	Multiple top covers detected.	Remove all top covers except for the top module in the library.
2014	Bottom cover missing.	<p>If the controller module cannot detect both a top and a bottom cover, the robotic mechanism will not move.</p> <ol style="list-style-type: none"> 1. Install the bottom cover on the bottom module in library. 2. Check the module interconnect cabling and module power cords.
2015	Top cover missing.	<p>If the controller module cannot detect both a top and a bottom cover, the robotic mechanism will not move.</p> <ol style="list-style-type: none"> 1. Install the top cover on the bottom module in library. 2. Check the module interconnect cabling and module power cords.
2016	Module alignment mechanism is not locked properly.	Ensure that the alignment mechanisms for all modules above the bottom module are engaged and locked.
2017	A communication problem between modules was detected.	<ol style="list-style-type: none"> 1. Ensure that all modules are powered on. 2. Ensure that all module interconnect cables are properly attached. 3. Ensure that the alignment mechanisms for all modules above the bottom module are engaged and locked.
2021	Database access error.	<ol style="list-style-type: none"> 1. Reboot the library.

Event Code	Message Text and Description	Details and Solution
		<ol style="list-style-type: none"> 2. If the error persists, restore the library configuration. See Configuring the Library on page 48.
2022	Drive has been hot removed while in active status as LUN master. Tape drives must be powered off before removing them from the library.	Reinsert the removed drive in the same position from which it was removed.
2023	Internal software error.	Reboot the library.
2024	Exception thrown by application not handled.	An unrecoverable error occurred. Retry the operation and if the error persists reboot the library.
2027	Move failed pulling cartridge from element.	Check for labels or cartridge misalignments that would prevent the cartridge from coming out of the slot or drive.
2028	Move failed inserting cartridge to element.	Check for labels or cartridge misalignments that would prevent the cartridge from being inserted into the slot or drive.
2029	Initialization failure due to robot front to back positioning.	<ol style="list-style-type: none"> 1. Check for obstructions, such as a cartridge sticking out, in the vertical pathway of the robotic assembly. 2. Ensure that the alignment mechanisms for all modules above the bottom module are engaged and locked. 3. Verify that the rack is level front to back and side to side. 4. Check to see if the robotic assembly is stuck in its locking mechanism. If so, move the robotic assembly out of the locking mechanism and then enable the locking mechanism properly.

Event Code	Message Text and Description	Details and Solution
2032	Initialization failure due to robot gripper positioning error.	Check for obstructions, such as a cartridge sticking out, in the vertical pathway of the robotic assembly.
2033	Initialization failure due to robot vertical positioning error.	
2034	Cable to spooling mechanism has failed during initialization.	Ensure that the spooling mechanism is fully seated in the controller module and installed correctly with the robotic assembly.
2035	Initialization failure due to robot gripper positioning error.	Check for obstructions in the gripper pathway of the robot such as a cartridge sitting in the shuttle of the robot.
2036	Unintended termination of application process.	Reboot or power cycle system.
2037	Robotic firmware version upgrade failed.	Reboot or power cycle system. If the problem persists, contact Spectra Logic Technical Support. See Contacting Spectra Logic on page 8 .
2038	Lost connection to Module.	Ensure that all modules are powered and have the interconnect cable properly attached. Reboot or power cycle the system.
2039	Cartridge left in robot gripper, unable to be moved to any open location.	Enable EE ports and ensure that some of them are free. Then power cycle library. If still failing, open covers and remove cartridge manually from gripper.
2040	Wellness test failed with critical error.	See codes 2041-2051.
2041	Wellness test failed because of unit lock failed.	Ensure that the alignment mechanism is engaged in every module that is above another module in the library

Event Code	Message Text and Description	Details and Solution
2042	Wellness test failed because of top cover is missing.	Install the top cover on the top module of the library. Also check the module interconnect cabling and module power cabling. If the controller module cannot detect both a top and bottom cover the robot will not move.
2043	Wellness test failed because of top cover is missing.	Install the bottom cover on the bottom module of the library. Also check the module interconnect cabling and module power cabling. If the controller module cannot detect both a top and bottom cover the robot will not move.
2044	Wellness test failed because of drive power board has failed.	<ol style="list-style-type: none"> 1. Ensure that the drive power boards are fully seated in the module. 2. Power cycle the Library.
2045	Wellness test failed because of move media test failed.	Check for obstructions in the pathway of the robot such as a cartridge sticking out. Verify module alignment and frame alignment. Check if the robotic assembly is stuck in the lock mechanism. Move robotic assembly apart from lock mechanism and enable lock mechanism correctly.
2046	Wellness test failed because of drive communication test failed.	Remove and reseal the drive tray to ensure that the drive is fully seated. If the issue persists then reset the drive. Check the drive dump for more information. See Maintaining the Library on page 127 .
2047	Wellness test failed because the barcode scanning test failed.	Verify that there is no obstruction in front of the barcode scanning module on the cartridge table located on the robotic assembly. If the error persists replace the robotic assembly. Contact Spectra Logic Technical Support for assistance.

Event Code	Message Text and Description	Details and Solution
2051	Wellness test failed because of the failing robotics test.	Check for obstructions in the pathway of the robot such as a cartridge sticking out. Verify module alignment and frame alignment. Check if the robotic assembly is stuck in the lock mechanism. Move robotic assembly apart from lock mechanism and enable lock mechanism correctly. Ensure that the spooling cable is fully seated in the controller module and connected correctly to the robotic assembly.
2052	An open magazine was detected in one or more modules and the robot movement has been stopped.	Ensure that all magazines are completely inserted and properly locked. Do not open magazines using the emergency release while the library is operating and the robot is moving.
2053	An open top cover was detected and the robot movement has been stopped.	Ensure that the top cover is completely inserted and properly locked. Do not open top cover using the emergency release while the library is operating and the robot is moving.
2054	An open bottom cover was detected and the robot movement has been stopped.	Ensure that the bottom cover is completely inserted and properly locked. Do not open bottom cover using the emergency release while the library is operating and the robot is moving.
2055	An open unit lock was detected and the robot movement has been stopped.	Ensure that all unit locks are properly locked. Do not open unit locks using the emergency release while the library is operating and the robot is moving.
2056	Initialization failure due to picker push pull positioning error.	Check for obstructions in the horizontal pathway of the robotic assembly such as a cartridge sticking out or a cable impeding progress.

Event Code	Message Text and Description	Details and Solution
2057	Robotic shipping lock in incorrect position.	Access the picker assembly and manually move the shipping lock lever to either a locked or unlocked position. After moving the shipping lock to the one of the correct positions, reboot the library.
2061	Move failed pulling cartridge from drive.	Check for labels or cartridge misalignments that would prevent the cartridge from coming out of the drive.
2062	Move failed inserting cartridge to drive.	Check for labels or cartridge misalignments that would prevent the cartridge from coming out of the drive.
2063	Move failed positioning picker in front of drive.	Contact Spectra Logic Technical Support. See Contacting Spectra Logic on page 8 .
2064	Library test failed with critical error.	Contact Spectra Logic Technical Support. See Contacting Spectra Logic on page 8 .
2065	Library startup process failed because of robotics initialization issue.	Contact Spectra Logic Technical Support. See Contacting Spectra Logic on page 8 .
2066	Library startup process failed during inventory scan.	Contact Spectra Logic Technical Support. See Contacting Spectra Logic on page 8 .
2067	For safety reason the robot movement was halted in place.	Ensure that all magazines, top or bottom covers and unit locks are completely inserted and properly locked. Do not open magazines using the emergency release or remove covers or unit locks while the library is operating and the robot is moving. Ensure that all modules are powered and have the interconnect cable properly attached.

Event Code	Message Text and Description	Details and Solution
2068	An emergency stop condition was detected in one or more modules and prevented the robotic assembly from initialization.	Ensure that all magazines, top or bottom covers and unit locks are completely inserted and properly locked. Please insert all open magazines and install all necessary covers and unit locks before powering on the library. Ensure that all modules are powered and have the interconnect cable properly attached.
2069	Initialization failure due to barcode reader error.	Contact Spectra Logic Technical Support. See Contacting Spectra Logic on page 8 .
2070	Inventory scan failed because of Elevator axis problem.	Check for obstructions in the vertical pathway of the robot such as a cartridge sticking out. Verify module alignment and rack alignment.
2071	Cartridge on picker when trying to scan.	Verify that there is no obstruction in front of the barcode scanning module on the cartridge table located on the robotic assembly. If the error persists replace the robotic assembly. Contact Spectra Logic Technical Support for assistance.
2072	Top cover detected at an incorrect position.	Examine the library and adjust the cover to the proper position.
2073	Bottom cover detected at an incorrect position.	Examine the library and adjust the cover to the proper position.
2074	The library startup failed due to a GPIO error.	Reboot or power cycle system.
2075	The library startup failed due to an error when trying to open the robotic serial port.	Reboot or power cycle system.
2076	I2C bus signals invalid.	Contact Spectra Logic Technical Support. See Contacting Spectra Logic on page 8 .
2077	Failed to store Calibration Data to Chassis.	Reboot or power cycle system.

Event Code	Message Text and Description	Details and Solution
2079	Could not upgrade barcode reader firmware.	Reboot or power cycle system.
2080	Cartridge lost while inserting it into slot/drive.	Check the source/destination element and ensure that there are no obstructions in the pathway of the robot.

WARNING EVENTS

Event Code	Message Text and Description	Details and Solution
4000	A reported drive canister fan speed is too slow.	Ensure that there are no obstructions to the drive fans.
4002	A drive sent a clean request.	Clean the drive with an approved cleaning cartridge.
4003	The drive configuration failed.	<ol style="list-style-type: none"> 1. Remove the drive from the library, reinsert it and then retry the operation. 2. If the drive installed is a different LTO generation than the drive previously installed, reset the library defaults and then reconfigure the drive. 3. Check the drive dump for more information. See Maintaining the Library on page 127.
4004	The drive status request failed.	<ol style="list-style-type: none"> 1. Remove the drive from the library, reinsert it and then retry the operation. 2. If the problem persists, reset the drive. 3. Check the drive dump for more information. See Maintaining the Library on page 127.
4005	Drive is reporting a critical TapeAlert.	<ol style="list-style-type: none"> 1. Power cycle the drive and then verify whether the drive reports the same TapeAlert. 2. Check the drive dump for more information. See Maintaining the Library on page 127.
4006	A drive temperature reported is above the threshold.	<ol style="list-style-type: none"> 1. Verify that the drive fan is spinning and not obstructed. 2. Verify that the ambient temperature is within specification.

Event Code	Message Text and Description	Details and Solution
4007	Cartridge error.	<ol style="list-style-type: none"> 1. Remove the cartridge and inspect it for damage. 2. Retry the operation with another cartridge.
4008	Cleaning tape expired.	Discard the cleaning cartridge and retry the cleaning operation with a new cleaning cartridge.
4009	Firmware upgrade of one or multiple expansion modules failed.	<p>The controller module must be able to communicate with a powered on and connected expansion module to perform the upgrade.</p> <ol style="list-style-type: none"> 1. Reseat the expansion module controller. 2. Check the module interconnect cable and power connections. 3. Retry the firmware upgrade.
4010	Drive is not compatible with this library.	Remove the incompatible drive. Only install drives that are supported by the library.
4012	Move cartridge operation failed due to drive issue.	<ol style="list-style-type: none"> 1. Check events occurring at the same time for drive problems. 2. Retry the operation with the same source and destination. If the problem persists, retry the operation with a different cartridge in the same drive. 3. Check the drive dump for more information. See Maintaining the Library on page 127.
4014	Library test failed due to a drive issue.	<ol style="list-style-type: none"> 1. Verify the test parameters and then retry the test. 2. Check the library event log for events associated with this drive. See Maintaining the Library on page 127.

Event Code	Message Text and Description	Details and Solution
		<ol style="list-style-type: none"> 3. Check the drive dump for more information. See Maintaining the Library on page 127.
4015	Power supply has failed. Redundancy is not available.	<ol style="list-style-type: none"> 1. Ensure that all power supplies are installed properly. 2. Verify that all power sources are supplying power that is within the product requirements.
4016	Backup configuration data to controller module failed.	<ol style="list-style-type: none"> 1. If possible, save the library configuration to a file.
4017	Restore configuration data from chassis failed.	<ol style="list-style-type: none"> 2. Power cycle the library and retry the operation.
4018	Firmware upgrade of one or more drives failed due to drive issue.	<ol style="list-style-type: none"> 1. Verify that the firmware file is correct for the drive. 2. Ensure that the drive is in a healthy state and does not have a cartridge loaded.
4019	General drive firmware bundle upgrade failure.	<ol style="list-style-type: none"> 3. Retry the operation.
4020	Database has been reset due to a problem that prevented the library from powering up.	Restore previously saved configuration data.
4021	Drive has been hot removed while in active status as data transfer device. Drives must be powered off before removing them from the library.	Reinsert the removed drive in the same position from which it was removed.
4024	One or two unit position transmitter/detector failures.	Contact Spectra Logic Technical Support. See Contacting Spectra Logic on page 8.
4025	Library test failed due to a cartridge error.	<ol style="list-style-type: none"> 1. Remove the cartridge and inspect it for damage. 2. Retry the operation with another cartridge.

Event Code	Message Text and Description	Details and Solution
4028	Drive cannot use this media due to it being an unknown or unsupported format. Possibly the media is the wrong generation of media.	Check that the LTO generation of the tape cartridge is the same generation indicated on the barcode label. Remove cartridges which are not compatible to your tape drives.
4029	Incompatible media move operation blocked by media barcode ID check.	Check if Media barcode label is matching LTO generation. Replace label or remove incompatible media from your system.
4030	Move cartridge operation failed due to media error.	Remove the cartridge and inspect it for damage. Retry the operation with another cartridge.
4041	Wellness test failed because of power supply redundancy test failed.	Ensure all power supplies are installed properly (two per module), and that each power supply is connected to a valid power source.
4044	One of the Library tests failed because of a source element or destination element is currently not accessible.	Contact Spectra Logic Technical Support. See Contacting Spectra Logic on page 8 .
4060	Connection to the KMIP server failed.	Verify username and password as well as all needed SSL certificates needed for connecting to the KMIP server. Verify that the KMIP server is reachable within the network.
4061	Key not found on KMIP server.	Verify that the requested key is available on the KMIP server. Check the KMIP server logs for additional details.
4062	Key creation on KMIP server failed.	Check the KMIP server logs for additional details about the key creation failure.
4063	KMIP configuration invalid.	Use the KMIP configuration wizard to verify the KMIP configuration.
4064	KMIP feature not licensed.	Disable KMIP or install appropriate license for KMIP feature.

Event Code	Message Text and Description	Details and Solution
4065	A tape alert flag was reported by a drive.	Contact Spectra Logic Technical Support. See Contacting Spectra Logic on page 8 .
4067	Cleaning cartridge will expire soon and should be replaced.	Replace the cartridge.
4072	No cleaning cartridge in partition available for auto cleaning.	Auto cleaning is enabled, but the partition contains no labeled cleaning cartridge. The library was unable to perform the auto clean function for one or more drives in this partition. Install a valid and labeled cleaning cartridge into the partition and then perform a load and unload on the drive that needs to be cleaned to initiate the auto cleaning.
4073	Medium source element empty.	Check the source slot visually and rescan inventory. Additionally check for valid and readable barcode label.
4074	Medium source element empty.	Check the source slot visually and rescan inventory. Additionally check for valid and readable barcode label.
4075	Cartridge lost while extracting it from slot/drive.	Check the source element and ensure that there are no obstructions in the pathway of the robot.
4077	Unlocking the right magazine failed.	Reboot the library and retry the operation. If the magazine needs to be removed to get access to the tape cartridges, first power down the library and then release the magazine manually. Only one magazine can be open at a time. If the problem persists, contact Spectra Logic Technical Support. See Contacting Spectra Logic on page 8

Event Code	Message Text and Description	Details and Solution
4078	Unlocking the left magazine failed.	Reboot the library and retry the operation. If the magazine needs to be removed to get access to the tape cartridges, first power down the library and then release the magazine manually. Only one magazine can be open at a time. If the problem persists, contact Spectra Logic Technical Support. See Contacting Spectra Logic on page 8
4079	Unlocking the mailslot failed.	Reboot the library and retry the operation. If the mailslot needs to be removed to get access to the tape cartridges, first power down the library and then release the entire magazine manually. Only one magazine can be open at a time. If the problem persists, contact Spectra Logic Technical Support. See Contacting Spectra Logic on page 8
4080	Wellness test failed with warning.	Contact Spectra Logic Technical Support. See Contacting Spectra Logic on page 8 .
4085	Too many retries of drive command needed because of UnitAttention or NotReady condition.	Contact Spectra Logic Technical Support. See Contacting Spectra Logic on page 8 .
4086	Move operation failed due to the inability accessing the database.	Ensure the network the library is connected to is operating normally and ensure the library is running the latest firmware. Library needs reboot.
4093	Could not obtain an IP address from DHCP server.	Check the network configuration settings and check if the DHCP server is reachable. Use the network configuration menu or unplug the network cable and plug it in after a few seconds to trigger an automatic reconfiguration of the network interface.

CONFIGURATION CHANGE EVENTS

Event Code	Message Text and Description
8000	The configuration of a drive changed.
8001	The drive was added or removed from the system.
8002	A partition was added, removed, or changed.
8003	An EE port bank was enabled or disabled.
8004	Drive firmware changed due to firmware upgrade.
8005	The configuration of hostname/domain name has changed.
8006	The email configuration settings have changed.
8007	The configuration of a date/time format changed.
8008	The system language setting changed.
8009	The timezone configuration has changed.
8010	A new partition was added.
8011	The network settings have changed.
8012	The firmware for all expansion modules has been upgraded.
8013	The NTP time synchronization configuration has changed.
8014	SSH access was enabled or disabled.
8015	Level of media generation checking has changed.
8016	Library reset to default settings invoked by user.
8017	Library firmware changed.
8018	The Unlabeled Media Support configuration has changed.
8019	Robotic firmware version upgraded.
8022	RMI/OCP Timeout configuration changed.
8024	Mailslot/Magazine access control configuration changed.
8025	Mailslot/Magazine automatic re-lock duration changed.

Event Code	Message Text and Description
8026	Robotics change detected.
8027	Power Board has changed.
8028	Power Supply has changed.
8029	The SNMP configuration changed.
8030	An SNMP target has been added.
8031	An SNMP target has been deleted.
8032	The SNMPv3 settings changed.
8033	The OCP module has been changed.
8034	Manual Drive reset executed.
8036	New chassis detected.
8037	Chassis has been removed.

INFORMATIONAL EVENTS

Event Code	Message Text and Description
9000	A tape alert flag was reported by a drive.
9001	A drive is present in the system but powered off.
9002	The library was powered on.
9003	A move media command was executed.
9004	Inventory scan was performed.
9005	The library was powered down from the front panel.
9006	The network interface was enabled.
9007	The network interface was disabled.
9008	The system time was synchronized with an SNTP server.
9009	A magazine was unlocked and opened.
9010	A magazine was closed and locked.
9011	An EE port bank was unlocked and opened.
9012	An EE port bank was closed and locked.
9013	A user logged into the RMI interface.
9014	A user logged out of the RMI interface.
9015	A user logged into the OCP interface.
9016	A user logged out of the OCP interface.
9024	Drive support ticket created.
9025	Library test started.
9026	Library test successfully finished.
9027	Library test stopped by user.
9028	Configuration backup to controller module was successful.
9029	Configuration restore from controller module was successful.

Event Code	Message Text and Description
9031	Library Health Status changed to "Status OK".
9032	Library health status changed to status "Warning".
9034	New system controller detected.
9035	New library chassis detected.
9037	The library was rebooted.
9038	The library was rebooted through user interface.
9041	Key on KMIP server created.
9042	Drive cleaning completed.
9043	Drive cleaning was started.
9045	Library configuration data failed to duplicate on to the controller module.
9046	Chassis fan speed could not be determined.

CHAPTER 9 - TECHNICAL SUPPORT

Spectra Logic Technical Support provides a worldwide service and maintenance structure, refined over many years to provide timely, professional service.



IMPORTANT

A valid BlueVision Software Support key is required in order to obtain technical support

Accessing the Technical Support Portal	187
Create an Account	187
Log Into the Portal	188
Opening a Support Ticket	189
Search for Help Online	189
Submit an Incident Online	192
Submit an Incident by Phone	194
Returns	195

ACCESSING THE TECHNICAL SUPPORT PORTAL

The Spectra Logic Technical Support portal provides access to the Knowledge Base, the current version of BlueVision software for the library, drive firmware, drive device drivers, and additional service and support tools. You can also open or update a support incident.

Create an Account

Access to User Guides and compatibility matrices does not require you to create an account. You must create a user account and log in to access Release Notes or repair documents, to download the latest version of BlueVision software, or to open a support incident.

1. Access the Technical Support portal login page at support.spectralogic.com.
2. On the home page, click **Register Now**.

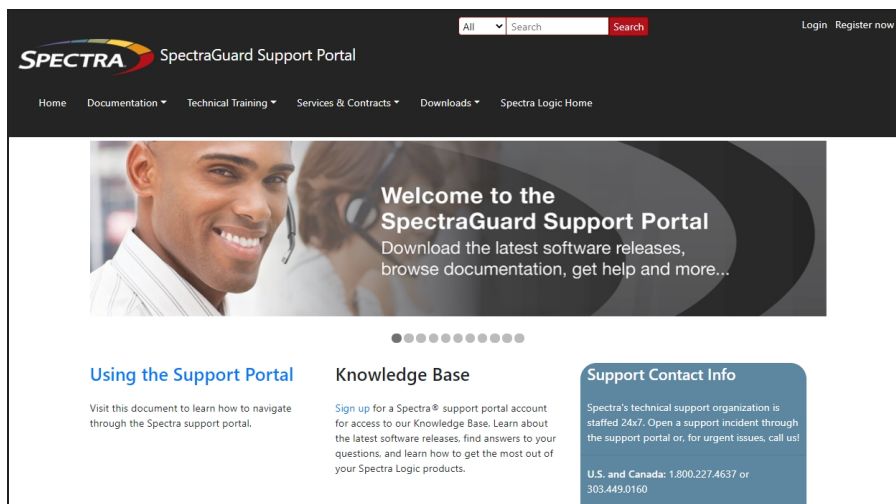
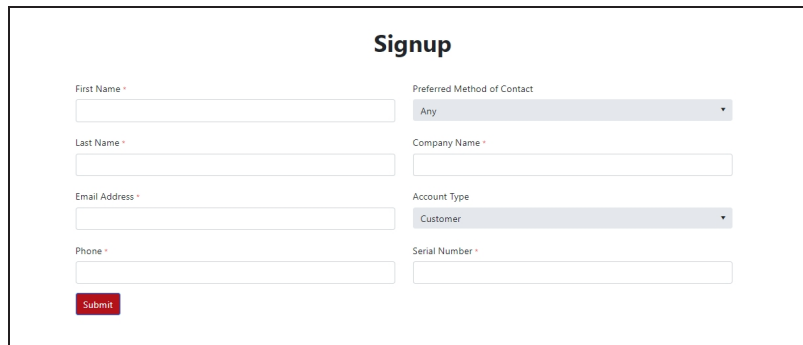

Figure 101 The Spectra Logic Technical Support portal home page.

3. Enter your registration information. Your account is automatically associated with the serial numbers of all Spectra Logic products owned by your site.
 - If you have an invitation, follow the link and enter the invitation code.



The image shows a web form titled "Signup". The form is organized into two columns. The left column contains four text input fields: "First Name", "Last Name", "Email Address", and "Phone". The right column contains three dropdown menus: "Preferred Method of Contact" (with "Any" selected), "Company Name", and "Account Type" (with "Customer" selected). Below the "Phone" field is a red "Submit" button.

Figure 102 The Signup screen.

- If you do not have an invitation, enter the requested information to create your account. When you are finished, click **Submit**.

When the account is approved, you receive an email with an initial password. Use your email address and the password provided in the email to log in to your account. After you log in, you can change your password if desired.

Log Into the Portal

Use your email address and password to log into the Technical Support Portal.

OPENING A SUPPORT TICKET

You can open a support incident using the Spectra Logic Technical Support portal or telephone.

Search for Help Online

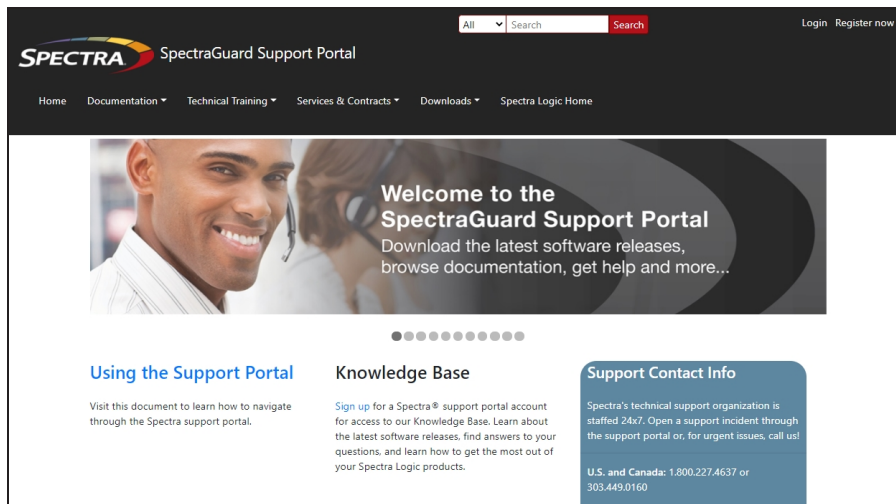

Figure 103 The Spectra Logic Technical Support portal home page.

1. Make notes about the problem, including what happened just before the problem occurred.
2. Gather the following information:
 - Your Spectra Logic customer number
 - Company name, contact name, phone number, and email address
 - The library serial number on the **Configuration>Settings** screen.
 - Type of host system being used
 - Type and version of host operating system being used
 - Type and version of host storage management software being used
3. If necessary, log in to the Support Portal by clicking **Login**, enter your **email address** and **password**, and click **Log in**.

Note: See [Technical Support](#) on page 186 if you have not previously created an account on the Technical Support portal.

4. From any page, select **Incident>Incidents & Inventory**.

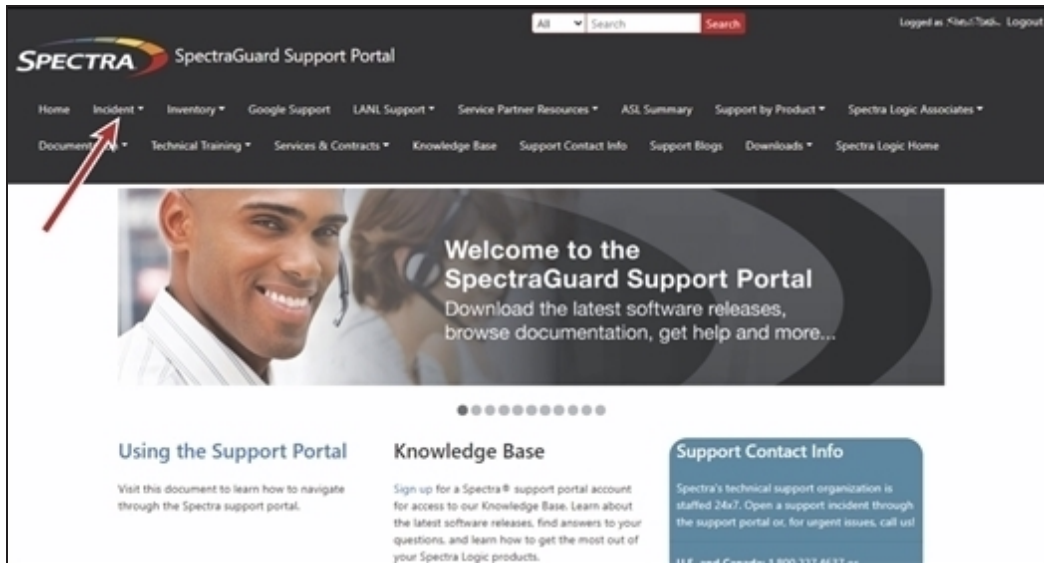

Figure 104 Select **Incidents>Incidents & Inventory**.

5. Select **Open or View Incidents**.

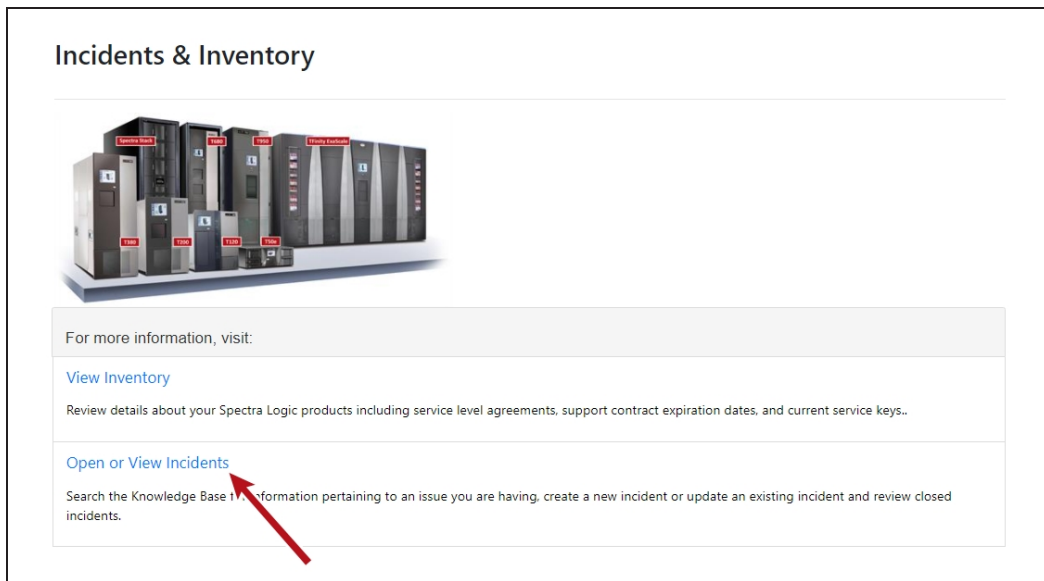

Figure 105 Select **Open or View Incidents**.

6. In the Search dialog box, enter a term or phrase about your problem (1) and click **Search** (2).

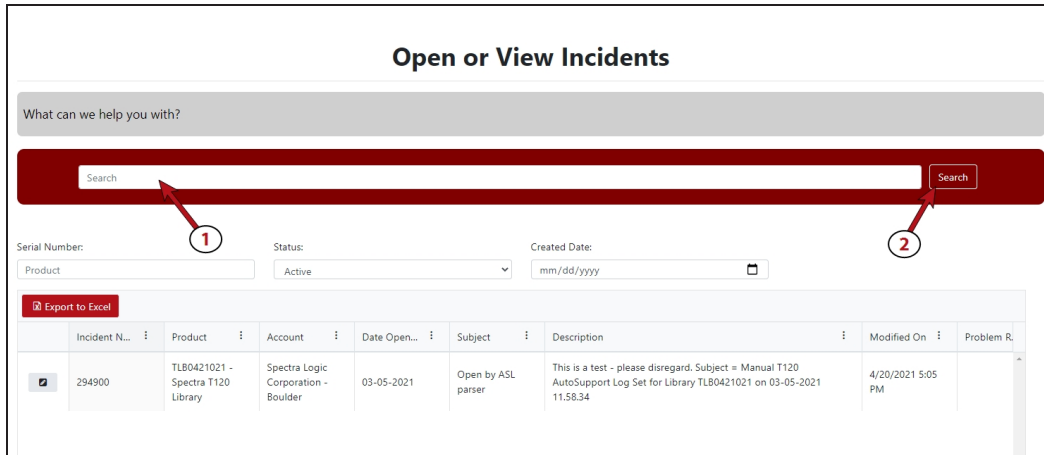

Figure 106 Enter a search phrase and click **Search**.

7. If the search does not provide an answer, click **Open a New Incident**.

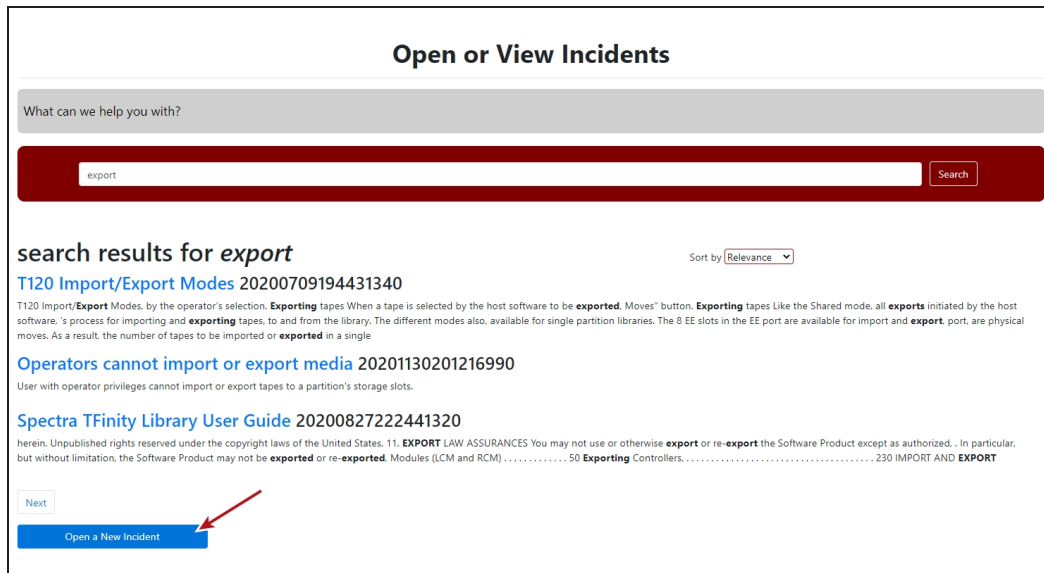

Figure 107 Click **Open a New Incident**.

8. On the Create Incident page, enter the requested information providing as much detail as possible. When you are finished, click **Submit**.

Create Incident

Severity *

Problem Description *

Email addresses to include in correspondence

Customer *

Product *

Select files...

DELIVERY Address For Shipping Parts

Confirm The Ship To Address

Submit

Figure 108 Enter information about your incident and click **Submit**.

Submit an Incident Online

1. Make notes about the problem, including what happened just before the problem occurred.
2. Gather the following information:
 - Your Spectra Logic customer number
 - Company name, contact name, phone number, and email address
 - The library serial number on the **Configuration>Settings** screen.
 - Type of host system being used
 - Type and version of host operating system being used
 - Type and version of host storage management software being used
3. If necessary, log in to the Support Portal by clicking **Login**, enter your **email address** and **password**, and click **Log in**.

Note: See [Technical Support on page 186](#) if you have not previously created an account on the Technical Support portal.

4. From any page, select **Inventory>My Inventory**.

5. Locate the row of the product for which you want to submit an incident and click **Create Incident**.

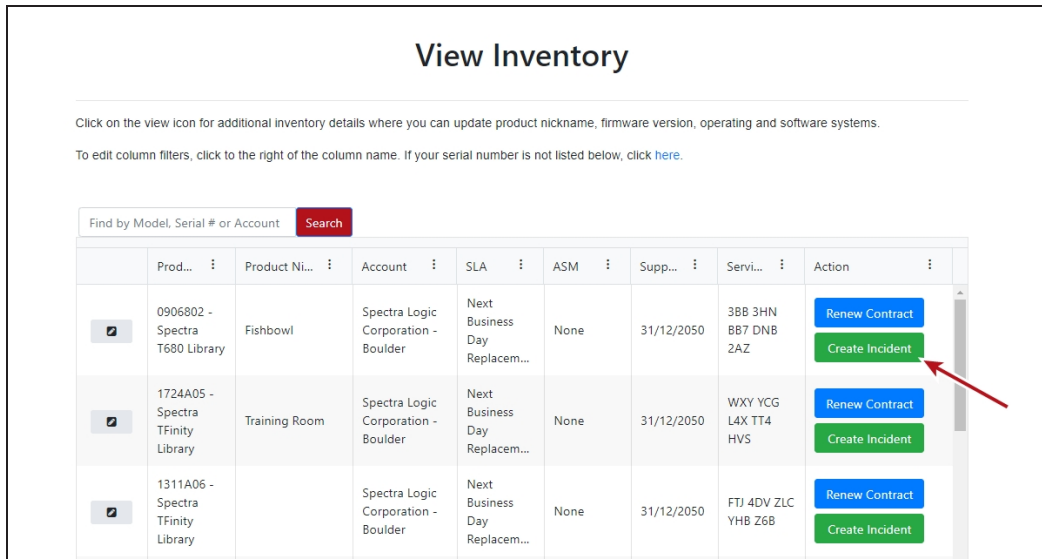

Figure 109 Click **Create Incident**.

6. On the Create Incident page, enter the requested information providing as much detail as possible. When you are finished, click **Submit**.

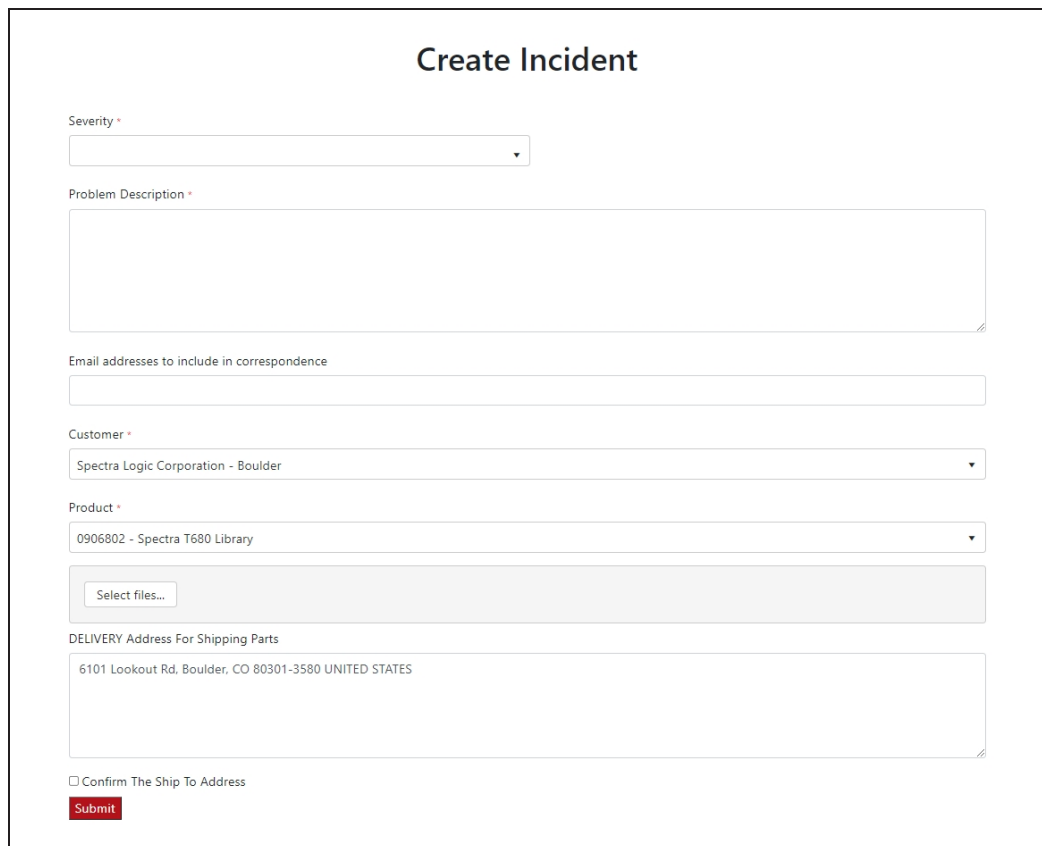

Figure 110 Enter information about your incident and click **Submit**.

Submit an Incident by Phone

Contact Spectra Logic Technical Support by phone using the information below.

Spectra Logic Technical Support	
Technical Support Portal: support.spectralogic.com	
United States and Canada Phone: Toll free US and Canada: 1.800.227.4637 International: 1.303.449.0160	Europe, Middle East, Africa Phone: 44 (0) 870.112.2185 Deutsch Sprechende Kunden Phone: 49 (0) 6028.9796.507
Additional international numbers available at support.spectralogic.com/home If you have a Spectra Logic Portal account, please log in for country-specific numbers at support.spectralogic.com/support-contact-info	

RETURNS

Your Technical Support representative may ask you to return a problem component to Spectra Logic for analysis and servicing. After you complete a replacement procedure, return the defective part using ALL of the packaging that the replacement part arrived in (including any anti-static bags or foam inserts).

**CAUTION**

Severe damage can occur if the component is not packaged correctly. You may be invoiced if it is damaged due to improper or insufficient packaging.

Use the return label and instructions that were included with the replacement part when preparing to ship the component you are returning. If you cannot locate these, contact Spectra Logic for another copy (see [Contacting Spectra Logic](#)). The return label and Return Merchandise Authorization (RMA) printed on it are used to associate the returned component with your account. To avoid being invoiced for failure to return the component, do not ship the component back to Spectra Logic without the RMA return label.

APPENDIX A - SPECIFICATIONS

This appendix provides specifications for the Spectra SL3 Tape library.

Physical Specifications	197
Rack Requirements	197
Environmental Specifications	199
Library Environmental Specifications	199
Electrical specifications	200
Regulatory specifications (CSA test conditions)	201
Default Settings	202
Barcode Label Specifications	206
Electrostatic discharge	209
Preventing Electrostatic Damage	209
Grounding Methods	209
Power Consumption and Cooling Requirements	210
LTO Tape Drive Specifications	211

PHYSICAL SPECIFICATIONS

Parameter	Unpackaged	Packaged
Height	5.2 inches (132 mm)	12.6 inches (320 mm)
Width	18.7 inches (475 mm)	27.6 inches (700 mm)
Depth	35.1 inches (892 mm)	45.7 inches (1160 mm)
Weight	Controller module: 44.1 lb (20.0 kg) Expansion module: 30.8 lb (14.0 kg)	Controller module: 66.1 lb (30.0 kg) Expansion module: 57.3 lb (26.0 kg)

Rack Requirements

The rack for the Spectra SL3 library must meet the following requirements.



CAUTION

You must locate the rack on a level, hard-surfaced floor, such as cement or tile. Do not place the rack on a carpeted floor or anywhere else that poses risk for static discharge that could damage your system or its drives.

The Spectra SL3 library is designed to fit in a standard 19-inch, 4-post rack. Keep the following in mind when selecting a rack:

- Make sure that the distance between the mounting surfaces on the front and rear posts is between 26.6 inches (67.5 cm) and 30.8 inches (78.2 cm).
 - Note:** If you are using the adaptors to install the rack-mount kit in a rack with circular mounting cutouts, the distance between the front and rear posts must be at least 28.1 inches (71.3 cm), and not more than 32.3 inches (82 cm).
- Allow approximately 3 inches (8 cm) of additional depth at the back of the rack for cable clearance.
- Some racks may require at least 2 inches (5 cm) of clearance between the front door frame and the front mounting posts of the rack to allow the door to close.

- Check your rack's specifications to make sure it accommodates the weight and depth of the Spectra SL3 library.
 - Notes:**
 - Spectra Logic does not support the use of a two-post rack with a SL3 library.
 - Threaded round hole racks are not supported.
 - An enclosed 19-inch, four-post rack is available for purchase from Spectra Logic. The rack has two doors and removable side panels. Contact Spectra Logic Sales for more information (see [Contacting Spectra Logic on page 4](#)).
- In earthquake prone areas, provide restraints as necessary.



WARNING

In earthquake- prone areas, the rack must have stabilizing equipment or be anchored to the floor to eliminate the risk of tipping, which could lead to personal injury.

ENVIRONMENTAL SPECIFICATIONS

Library Environmental Specifications

Mode	Dry-bulb Temperature	Maximum Temperature Rate of Change ^a	Relative Humidity (non-condensing)	Maximum Humidity Rate of Change	Maximum Altitude
Allowable Environment	5° C to 35° C (41° F to 95° F)	10° C per hour 18° F per hour	10% to 80% 22° C dew point max (72° F)	5% per hour with no condensation	5000 m (16,450 ft)
Recommended Environment	10° C to 30° C (50° F to 86° F)	10° C per hour 18° F per hour	10% to 80% 22° C dew point max (72° F)	5% per hour with no condensation	5000 m (16,450 ft)

Storing ^b and Shipping (Non-Operating) Environment Specification	
Humidity	5% to 90% (non-condensing)
Temperature	-40° F to 140° F (-40° C to 60° C)
Altitude	Sea level to 40,000 ft (12,192 m)

^a The temperature and humidity must be allowed to stabilize in the specified ambient environment for 24 hours.

^bThe library is in its original packaging. The packaging is designed to protect the library from condensation caused by extreme temperature variations of 27° F (15° C) or more. When the library is moved from a cold storage environment to a warm operating environment, it must be acclimated in its packaging for at least 24 hours before opening to prevent serious condensation damage from occurring.

ELECTRICAL SPECIFICATIONS

Parameter	Specification
Current	9.5 A
Voltage	100-240 V
Input Frequency	50-60 Hz
MAX Power	230 watts

REGULATORY SPECIFICATIONS (CSA TEST CONDITIONS)

Note: The CSA test conditions might differ from the product specification limits.

Parameter	Tested Condition or Value
Equipment mobility	Stationary - rack mount
Connection to the mains	Pluggable - Type A
Operating condition	Continuous
Access location	Operator accessible
Over voltage category (OVC)	OVCII
Mains supply tolerance (%) or absolute mains supply values	-10%, +6%
Tested for IT power systems	No
IT testing, phase-phase voltage (V)	N/A
Class of equipment	Class I
Considered current rating (A)	20 A (branch circuit protection)
Pollution degree (PD)	PD 2
IP protection class	IPXO
Altitude during operation (m)	Maximum 6565 feet (2000 meters)
Altitude of test laboratory (m)	125 feet (38 meters)
Mass of equipment (kg)	Maximum 55.1 lb (25 kg)
Manufacturer's Declared Ambient (OC)	104° F (40° C)

DEFAULT SETTINGS

Parameter	Default Setting	Reset During Reset Default Settings?
Users and Passwords		
Administrator login	User: administrator Password: blank	No
User login	User: user Password: blank	No
Service login (requires admin pwd in addition to service pwd)	User: service Password: ser001	No
Security login	User: security Password: sec001	No
Network Configuration (EthO)		
DHCP	Enabled	
Host name	Blank	
IP address	(obtain from DHCP)	
Subnet mask	(obtain from DHCP)	
Default gateway	(obtain from DHCP)	
Network Configuration		
IPv4	Enabled	No
DHCPv4	Enabled	No
IPv6	Disabled	No
Static V6	Disabled	No
Stateless V6	Disabled	No
DNS Configuration	Blank	No
Network Access Services		
Primary network interface (ethO)	Enabled	

Parameter	Default Setting	Reset During Reset Default Settings?
SSH	Enabled	
SSL	Disabled	
LDAP	Disabled	Disabled with configuration retained
Slots		
Mailslots	Disabled	Yes
Magazines/Mailslots Allow user "User" access	Disabled	Yes
Reserved slots	0	Yes
Partitions	Disabled (no partitions)	All deleted leaving a single partition
Date and Time		
NTP /SNTP setting	Disabled	Configuration retained
Date	Blank or existing	
Time	Blank or existing	
Time zone	GMT	
Email notifications (SMTP)	Disabled	Disabled with configuration retained
SNMP/SMI-S		
SNMP v1, v2	Disabled	Disabled with configuration retained
SCSI Defaults		
Library product ID - INQUIRY product ID string (Std Inquiry page)	Python	
Library vendor ID - INQUIRY vendor ID string (Std Inquiry page)	Spectra	
SCSI element addressing	Starting element addresses	Yes

Parameter	Default Setting	Reset During Reset Default Settings?
	<p>Values in decimal:</p> <ul style="list-style-type: none"> • Slot: 1001 • Picker: NA • Drives: 1 • I/E slots: 101 <p>Values in hexadecimal:</p> <ul style="list-style-type: none"> • Slot: Ox3E9 • Picker: NA • Drives: Ox1 • I/E slots: Ox65 	
Miscellaneous Settings		
Return drive serial numbers to host	Enabled	
Return barcodes to host (RES SCSI data)	Enabled	
Barcode format and length returned to host	8 digits, left justified	Yes
Language settings	English	Yes
Miscellaneous Settings Continued		
Auto unload (library controlled unload)	Enabled	
Log tracing	Continuous, all levels selected	Yes
Ignore barcode media ID	Disabled	Yes
All licensed features	Disabled	Disabled, configuration retained where possible
Licenses	Not applicable	Not deleted
OCP		
Barcode format displayed on OCP	8 digits, left justified	Yes
OCP contrast		No

Parameter	Default Setting	Reset During Reset Default Settings?
Screen saver		Yes
Drive Defaults		
Drive speed and topology setting	Auto speed/Fabric	Yes
Drive hosting the library LUN	Drive 1 or the lowest numbered existing drive	Yes
Drive power	All drives powered on	Yes
Auto clean	Disabled	Yes

BARCODE LABEL SPECIFICATIONS

Symbology

The barcode labeling scheme used on Spectra Logic certified media uses the barcode symbology of USS-39. You can obtain a complete description and definition of this symbology from the *Automatic Identification Manufacturers (AIM) specification*, the *Uniform Symbol Specification (USS-39)*, and the *ANSI MH10.8M-1993 ANSI Barcode specification*.

Application and Orientation

The barcode label must be applied to the cartridge so that it fits within the label recess on the edge of the cartridge without curling up on the sides or ends. The label must be oriented so that the barcode characters are along the edge closest to the hub side of the cartridge.

Printed Characters

The label can have human-readable alphanumeric characters printed along the top or bottom edge of the label provided there is no conflict or interference with the automation code. This text must include the barcode data, but can also include additional text. The format and colors of the human readable characters is up to the customer and label vendor. For location restrictions, see [Specifications on page 196](#).

Note: When using barcode labels with alphanumeric characters along the bottom edge, the label must be positioned so that barcode is at least 13.72 mm below the top edge of the cartridge to ensure that the barcode reader can read the label.

Barcode Data

The library supports barcode data strings consisting of from 1 to 16 characters, including an optional checksum character. Quiet zones precede and follow the start and stop characters.

The barcode data string on standard Spectra Logic barcode labels consists of a start character, eight alphanumeric characters, a checksum character, and the stop character. Quiet zones precede and follow the start and stop characters.

- The first six (6) characters following the start character can be any combination of upper case A-Z or 0-9 (for example, ABC123) to identify the cartridge Volume Serial Number. The use of "CLN" and "DG{space}" at the beginning of the volume identifier is reserved.
 - The volume identifier "CLN vnn " is reserved for cleaning cartridges. When a drive requires cleaning, it requests a specific type of cleaning cartridge.
 - The " v " field is an alphanumeric field to identify cleaning cartridge applications, "U" for Universal Cleaning Cartridges or a drive unique identifier.
 - The " nn " alphanumeric field is used to track individual cleaning cartridge activity (that is, usage and life).
 - The volume identifier "DG{space} vnn " is reserved for diagnostic and service cartridges.

- The last two (2) characters are the media identifier and indicate the cartridge Media Type (for example, “L” for LTO and “6” for an LTO-6 cartridge. In IBM LTO tape drives, the value of the media identifier on cleaning cartridges is ignored, although a valid value must be present.
- The barcode string can be printed in either direction on the label and must begin and end with a valid start/stop character (*).
- The label must be printed so that barcode data is positioned along the edge of the label that is closest to the hub side of the cartridge.

The *AIM Uniform Symbol USS-39* specification provides detailed information about the format of the start character, the series of characters that make up the barcode data, the optional checksum character, and the stop character.

Detailed Specifications for LTO Cartridge Barcodes

Appendix A shows the dimensional specifications for LTO labels with the alphanumeric characters above the barcode.

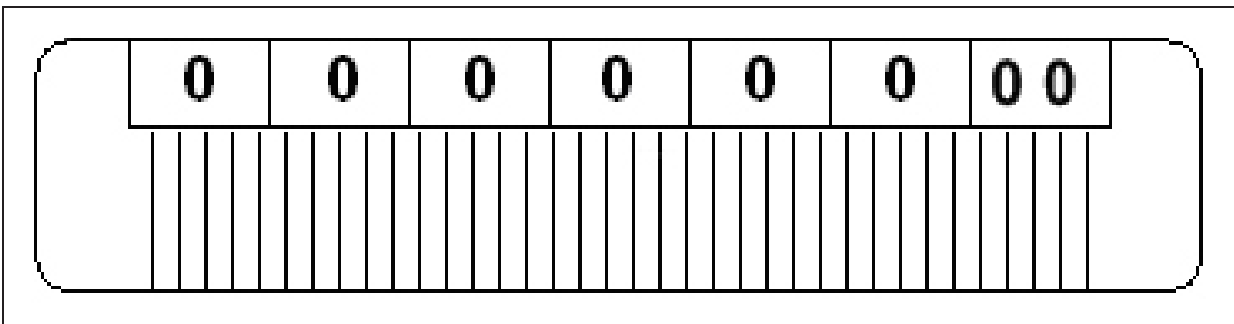

Figure 111 Barcode specifications for LTO media; alphanumeric characters on top.

Note: When using barcode labels with alphanumeric characters along the bottom edge, the label must be positioned so that barcode is at least 13.72 mm below the top edge of the cartridge to ensure that the barcode reader can read the label.

LTO Barcode Element Specifications

For the official IBM barcode label specification, see <https://ibm.com/support/docview.wss?uid=ssg1S7000429>. Unless otherwise specified, tolerances are $X.XXX \pm 0.127$ mm, $X.XXX \pm 0.762$ mm.

- Minimum symbol height is 11.1 mm, measured to the inside of the label’s edge.
- The wide-to-narrow ratio is 2.75.
- The narrow element width is 0.432 mm +0.03 mm or -0.076 mm.
- The nominal width of the wide spaces and bars is 1.188 mm.
- The inter-character gap is 0.432 mm +0.03/-0.076 mm.

- The minimum quiet zone at the beginning and end of a printed barcode string is 4.32 mm (10 times the narrow element width).
- The total nominal barcode string length (including quiet zones) is 74.088 mm.
- The edge of the barcode is the edge of the printed area associated with the bar. The edge roughness is the transition encountered as a horizontal line is moved vertically from all black to all white. The edge roughness maximum is 0.038 mm.
- Variation between all bars, white and black, must be less than ± 0.0381 mm.

LTO Physical Label Specifications

- Label stock must fit within the label recess on the face of the cartridge without curling up on the sides or ends (79 mm X 17 mm $+0/-0.8$).
- Minimum length sufficient for the quiet zones, start-stop, and data characters (nominal 74.088 mm).
- Minimum width no less than 1.5 mm narrower than the cartridge label recess width. Corners are cut with a 1.5 mm radius.
- Maximum label thickness, including the RFID tag, if present, together with any associated layers and adhesives cannot exceed 0.40 mm.
- The label and adhesive must have an environmental performance to match or exceed the environmental specifications of the cartridge to which it is applied.

ELECTROSTATIC DISCHARGE

To prevent damaging the system, be aware of the precautions you must follow when setting up the library or handling parts. A discharge of static electricity from a finger or other conductor may damage system boards or other static-sensitive devices. This type of damage may reduce the life expectancy of the device.

Preventing Electrostatic Damage

To prevent electrostatic damage, observe the following precautions:

- Always be properly grounded when touching a static-sensitive component or assembly.
- Avoid hand contact by transporting and storing products in static-safe containers.
- Keep electrostatic-sensitive parts in their containers until they arrive at static-free workstations.
- Place parts on a grounded surface before removing them from their containers.
- Avoid touching pins, leads, or circuitry.

Grounding Methods

There are several methods for grounding. Use one or more of the following methods when handling or installing electrostatic-sensitive parts:

- Use a wrist strap connected by a ground cord to a grounded workstation or computer chassis. Wrist straps are flexible straps with a minimum of 1 megohm (± 10 percent) resistance in the ground cords. To provide proper ground, wear the strap snug against the skin.
- Use heel straps, toe straps, or boot straps at standing workstations. Wear the straps on both feet when standing on conductive floors or dissipating floor mats.
- Use conductive field service tools.
- Use a portable field service kit with a folding static-dissipating work mat.

If you do not have any of the suggested equipment for proper grounding, have an authorized reseller install the part.

Note: For more information on static electricity, or assistance with product installation, contact your authorized reseller.

POWER CONSUMPTION AND COOLING REQUIREMENTS

The power and cooling requirements for the library depend on the number and type of drives installed and number of library modules. The following table provides the maximum power consumption and heat load for the base module fully loaded with half-height and expansion modules fully loaded with half-height drives. Use this information to calculate the total maximum power consumption and heat load values, which can be used to build a power budget for the library.

All values are measured at the AC input and include power supply efficiency. The values are averages of observed hardware. In general, the lighter the load on the power supplies, the less efficient they are. The power supply efficiency in turn affects the power draw of all components.

Component	Power Consumption (watts)	Heat Load, Continuous (BTU/hour)
Base SL3 Library	230 maximum	784 maximum
LTO-9 Fibre Channel or SAS Half-Height	• Read/write: 35	Read/write: 119
LTO-8 Fibre Channel or SAS Half-Height	• Read/write: 43	Read/write: 146
LTO-7 Fibre Channel or SAS Half-Height	• Read/write: 31	Read/write: 106
LTO-6 Fibre Channel	• Read/write: 28	Read/write: 95
LTO-5 Fibre Channel	• Read/write: 37	Read/write: 126

LTO TAPE DRIVE SPECIFICATIONS

This section provides specifications for the LTO drives supported by the library. See [Tape Media Specifications on page 555](#) for information about the media used in the library.

Note: LTO drives and media are also referred to as Ultrium or LTO Ultrium drives and media.

LTO-9 Drive

When connecting to a Fibre Channel network, LTO-9 Fibre Channel drives will attempt to connect at 8 Gb/second, but will auto-negotiate down to 4 Gb/second, or 2 Gb/second, depending on the requirements of the port to which the drive is connected.

LTO-9 SAS drives attempt to connect at 12 Gb/second, but auto-negotiate down to 6 Gb/second or 3 Gb/second, depending on the requirements of the port to which the drive is connected.

Parameter	Specification
Maximum sustained transfer rate ^a ^b	300 MB/second, native 750 MB/second, compressed
Speed matching range	177 MB/second to 400 MB/second
Average space record time	TBD
Encryption capability	AES 256-GCM
WORM capability	Yes
MTBF	250,000 hours at 100% duty cycle
Uncorrected error rate, calculated	1×10^{-20} bits
Power consumption	Read/write: 34 watts typical Idle: TBD

^aAssuming a 2.5:1 compression ratio. Compression throughput depends on the type of data.

^bThis is a per-drive value. Total sustained transfer rate for the library depends on the number of drives installed in the library.

LTO-8 Drive

When connecting to a Fibre Channel network, LTO-8 Fibre Channel drives will attempt to connect at 8 Gb/second, but will auto-negotiate down to 4 Gb/second, or 2 Gb/second, depending on the requirements of the port to which the drive is connected.

LTO-8 SAS drives attempt to connect at 6 Gb/second, but auto-negotiate down to 3 Gb/second or 1.5 Gb/second, depending on the requirements of the port to which the drive is connected.

Parameter	Specification
Maximum sustained transfer rate ^a ^b	300 MB/second, native 750 MB/second, compressed
Speed matching range	112 MB/second to 360 MB/second
Average space record time	59 seconds
Encryption capability	AES 256-GCM
WORM capability	Yes
MTBF	250,000 hours at 100% duty cycle
Uncorrected error rate, calculated	1×10^{-19} bits
Power consumption	Half-height: • Read/write: 43 W Idle: 14 W

LTO-7 Drive

When connecting to a Fibre Channel network, LTO-7 Fibre Channel drives attempt to connect at 8 Gb/second, but auto-negotiate down to 4 Gb/second, or 2 Gb/second, depending on the requirements of the port to which the drive is connected.

LTO-7 SAS drives attempt to connect at 6 Gb/second, but auto-negotiate down to 3 Gb/second or 1.5 Gb/second, depending on the requirements of the port to which the drive is connected.

^aAssuming a 2.5:1 compression ratio. Compression throughput depends on the type of data.

^bThis is a per-drive value. Total sustained transfer rate for the library depends on the number of drives installed in the library.

Parameter	Specification
Maximum sustained transfer rate ^a ^b	300 MB/second, native 750 MB/second, compressed
Speed matching range	100 MB/second to 300 MB/second
Average space record time	56 seconds
Encryption capability	AES 256-GCM
WORM capability	Yes
MTBF	250,000 hours at 100% duty cycle
Uncorrected error rate, calculated	1×10^{-19} bits
Power consumption	<ul style="list-style-type: none"> Half-height: Read/write: 36 W Idle: 20 W

LTO-6 Drive

When connecting to a Fibre Channel network, LTO-6 Fibre Channel drives will attempt to connect at 8 Gb/second, but will auto-negotiate down to 4 Gb/second, 2 Gb/second, or 1 Gb/second, depending on the requirements of the port to which the drive is connected.

Parameter	Specification
Maximum sustained transfer rate ^c ^d	160 MB/second, native ^e 400 MB/second, compressed
Speed matching range	40 MB/second to 160 MB/second
Average space record time	77 seconds
Encryption capability	AES 256-bit

^aAssuming a 2.5:1 compression ratio. Compression throughput depends on the type of data.

^bThis is a per-drive value. Total sustained transfer rate for the library depends on the number of drives installed in the library.

^cAssuming a 2.5:1 compression ratio. Compression throughput depends on the type of data.

^dThis is a per-drive value. Total sustained transfer rate for the library depends on the number of drives installed in the library.

^eA 1 Gb interface speed will not stream an LTO-6 drive at 160 MB/second.

Parameter	Specification
WORM capability	Yes
MTBF	250,000 hours at 100% duty cycle
Uncorrected error rate	1×10^{-17} bits
Power consumption	Read/write: 28 watts typical Idle: 8 watts

APPENDIX B - REGULATORY INFORMATION

Note: To comply with the following regulations and standards, the library must be properly installed in an office or industrial environment with shielded cables and adequate grounding of the SCSI bus and the input power.

RECYCLING AND DISPOSAL

Disposal of waste equipment by users in private household in the European Union and Norway

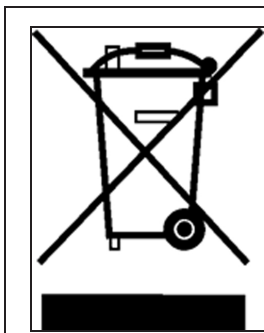

This symbol on the product or on its packaging indicates that this product must not be disposed of with your other household waste. Instead, it is your responsibility to dispose of your equipment by handling it over to a designated collection point for the recycling of waste electrical and electronic equipment. The separate collection and recycling of your waste equipment at this time of disposal will help to conserve natural resources and ensure that it is recycled in a manner that protects human health and the environment. For more information about where you can drop off your waste equipment for recycling, please contact your local city office, your household waste disposal service or the shop where you purchased the product.

CE MARK



The CE mark is a mandatory conformity mark on many products placed on the single market in the European Economic Area (EEA). The CE marking certifies that a product has met EU consumer safety, health or environmental requirements.

CCL MARK



FCC (UNITED STATES)

The computer equipment described in this manual generates and uses radio frequency (RF) energy. If the equipment is not installed and operated in strict accordance with the manufacturer's instructions, interference to radio and television reception might result.



This equipment complies with Part 15 of the FCC Rules. Operation is subject to the following conditions: (1) This device may not cause harmful interference, and (2) this device must accept any interference received, including interference that may cause undesired operation.

Part 15, Class A, of the FCC Rules, is designed to provide reasonable protection against radio and television interference in a residential installation. Although the equipment has been tested and found to comply with the allowed RF emission limits, as specified in the above-cited Rules, there is no guarantee that interference will not occur in a particular installation. Interference can be determined by turning the equipment off and on while monitoring radio or television reception. The user may be able to eliminate any interference by implementing one or more of the following measures:

- Reorient the affected device and/or its receiving antenna.
- Increase the distance between the affected device and the computer equipment.
- Plug the computer and its peripherals into a different branch circuit from that used by the affected device.
- If necessary, consult an experienced radio/television technician for additional suggestions.

CANADIAN VERIFICATION

This Class A digital apparatus meets all requirements of the Canadian Interference-Causing Equipment Regulations (ICES-003, Class A).